



Installation Guide

VLT[®] Parallel Drive Modules

250–1200 kW



vlt-drives.danfoss.com



RSPSupply - 1-888-532-2706 - <https://www.RSPSupply.com>
See the product details here



RSPSupply - 1-888-532-2706 - <https://www.RSPSupply.com>
See the product details here

Contents

1 Introduction	4
1.1 Purpose of the Manual	4
1.2 Additional Resources	4
1.3 Document and Software Version	4
1.4 Approvals and Certifications	4
1.5 Disposal	4
2 Safety	5
2.1 Safety Symbols	5
2.2 Qualified Personnel	5
2.3 Safety Precautions	5
3 Product Overview	7
3.1 Intended Use	7
3.2 Drive Modules	8
3.3 Control Shelf	9
3.4 Wire Harness	10
3.5 DC Fuses	10
4 Mechanical Installation	11
4.1 Receiving and Unpacking the Unit	11
4.1.1 Items Supplied	11
4.1.2 Lifting the Unit	12
4.1.3 Storage	12
4.2 Requirements	14
4.2.1 Environmental	14
4.3 Installing the Drive Modules	16
4.4 Installing the Control Shelf	18
5 Electrical Installation	19
5.1 Safety Instructions	19
5.2 Electrical Requirements for Certifications and Approvals	20
5.3 Wiring Diagram	21
5.4 Fuses	22
5.5 Electrical Kit Installation	24
5.6 DC Bus Fuse Installation	24
5.7 Motor Connections	24
5.7.3 Motor Terminal Connections	26
5.7.3.1 Motor Cable	26
5.7.3.2 Motor Terminal Connections in 2-Drive Module Systems	27

5.7.3.3 Motor Terminal Connections in 4-Drive Module Systems	27
5.8 Mains Connections	28
5.8.1 AC Mains Terminal Connections	28
5.8.1.1 Mains Terminal Connections in 2-Drive Module Systems	28
5.8.1.2 Mains Terminal Connections in 4-Drive Module Systems	29
5.8.2 12-Pulse Disconnecter Configuration	29
5.8.3 Discharge Resistors	30
5.9 Control Shelf Installation	31
5.10 Control Wiring Connections	31
5.10.1 Control Cable Routing	32
5.10.2 Control Wiring	33
5.10.2.1 Control Terminal Types	33
5.10.2.2 Wiring to Control Terminals	35
5.10.2.3 Enabling Motor Operation (Terminal 27)	35
5.10.2.4 Voltage/Current Input Selection (Switches)	35
5.10.2.5 RS485 Serial Communication	36
5.10.3 Safe Torque Off (STO)	36
5.11 Relay Output	36
5.12 EMC Recommendations	37
6 Initial Start-up	41
6.1 Pre-start Check List	41
6.2 Safety Instructions	42
6.3 Applying Power	42
6.4 Configuring the Drive System	43
6.5 Testing the Motor Operation	44
7 Specifications	45
7.1 Power-dependent Specifications	45
7.2 Mains Supply to Drive Module	59
7.3 Motor Output and Motor Data	59
7.4 12-Pulse Transformer Specifications	59
7.5 Ambient Conditions for Drive Modules	59
7.6 Cable Specifications	60
7.7 Control Input/Output and Control Data	60
7.8 Kit Dimensions	64
7.9 Fastener Tightening Torques	66
7.9.1 Tightening Torques for Terminals	66
8 Appendix	67
8.1 Disclaimer	67

8.2 Symbols, Abbreviations, and Conventions	67
8.3 Block Diagrams	68
Index	79

1 Introduction

1.1 Purpose of the Manual

This manual provides requirements for mechanical and electrical installation of the VLT® Parallel Drive Modules basic kit. Separate installation instructions for optional components - bus bars and back-channel cooling - are provided with those kits.

This guide includes information on:

- Wiring of mains and motor connections.
- Wiring of control and serial communications.
- Control terminal functions.
- Detailed tests that must be performed before start-up.
- Initial programming to verify proper functioning of the drive system.

The installation guide is intended for use by qualified personnel.

To install the drive modules and paralleling kit safely and professionally, read and follow the installation guide. Pay particular attention to the safety instructions and general warnings. Always keep this installation guide with the panel containing the VLT® Parallel Drive Modules components.

VLT® is a registered trademark.

1.2 Additional Resources

Other resources are available to understand functions and programming of the VLT® Parallel Drive Modules.

- The *VLT® Parallel Drive Modules Design Guide* contains detailed information about the capabilities and functionality of motor control systems using these drive modules, and provides guidance for designing this type of system.
- The *VLT® Parallel Drive Modules User Guide* contains detailed procedures for start-up, basic operational programming, and functional testing. Additional information describes the user interface, application examples, troubleshooting, and specifications.
- Refer to the *Programming Guide* applicable to the particular series of VLT® Parallel Drive Modules used in creating the drive system. The programming guide describes in greater detail how to work with parameters and provides application examples.

- The *VLT® FC Series, D-frame Service Manual* contains detailed service information, including information applicable to the VLT® Parallel Drive Modules.
- The *VLT® Parallel Drive Modules DC Fuses Installation Instructions* contain detailed information about installing the DC fuses.
- The *VLT® Parallel Drive Modules Bus Bar Kit Installation Instructions* contain detailed information about installing the bus bar kit.
- The *VLT® Parallel Drive Modules Duct Kit Installation Instructions* contain detailed information about installing the duct kit.

Refer to other supplemental publications and manuals, available from Danfoss. See drives.danfoss.com/knowledge-center/technical-documentation/ for listings.

1.3 Document and Software Version

This manual is regularly reviewed and updated. All suggestions for improvement are welcome. *Table 1.1* shows the document version and the corresponding software version.

Edition	Remarks	Software version
MG37K3xx	Added 230 V external power supply content	FC 102 (5.0x), FC 202 (3.0x), FC 302 (7.6x)

Table 1.1 Document and Software Version

1.4 Approvals and Certifications



Table 1.2 Approvals and Certifications

1.5 Disposal

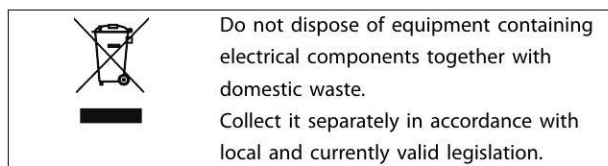

2 Safety

2.1 Safety Symbols

The following symbols are used in this manual:

▲WARNING

Indicates a potentially hazardous situation that could result in death or serious injury.

▲CAUTION

Indicates a potentially hazardous situation that could result in minor or moderate injury. It can also be used to alert against unsafe practices.

NOTICE

Indicates important information, including situations that can result in damage to equipment or property.

2.2 Qualified Personnel

Correct and reliable transport, storage, and installation are required for the trouble-free and safe operation of the VLT® Parallel Drive Modules. Only qualified personnel are allowed to install this equipment.

Qualified personnel are defined as trained staff, who are authorized to install equipment, systems, and circuits in accordance with pertinent laws and regulations. Also, the personnel must be familiar with the instructions and safety measures described in this manual.

2.3 Safety Precautions

▲WARNING

HIGH VOLTAGE

The drive system contains high voltage when connected to AC mains input. Failure to ensure that only qualified personnel install the drive system can result in death or serious injury.

- Only qualified personnel are allowed to install the drive system.

▲CAUTION

POTENTIAL HAZARD IN THE EVENT OF INTERNAL FAILURE

There is a risk of personal injury when the drive modules are not properly closed.

- Before applying power, ensure that all safety covers are in place and securely fastened.

▲WARNING

UNINTENDED START

When the drive system is connected to AC mains, the motor can start at any time. Unintended start during programming, service, or repair work can result in death, serious injury, or property damage. The motor can start via an external switch, a fieldbus command, an input reference signal from the LCP, a cleared fault condition, or remote operation using MCT 10 Set-up Software.

To prevent unintended motor start:

- Disconnect the drive system from AC mains.
- Press [Off/Reset] on the LCP, before programming parameters.
- The drive system, motor, and any driven equipment must be fully wired and assembled when the drive is connected to AC mains.

▲WARNING

DISCHARGE TIME

The drive module contains DC-link capacitors. Once mains power has been applied to the drive, these capacitors can remain charged even after the power has been removed. High voltage can be present even when the warning indicator lights are off. Failure to wait 20 minutes after power has been removed before performing service or repair work can result in death or serious injury.

1. Stop the motor.
2. Disconnect AC mains and remote DC-link supplies, including battery back-ups, UPS, and DC-link connections to other drives.
3. Disconnect or lock the PM motor.
4. Wait 20 minutes for the capacitors to discharge fully before performing any service or repair work.

▲WARNING

UNINTENDED MOTOR ROTATION WINDMILLING

Unintended rotation of permanent magnet motors creates voltage and can charge the capacitors in the drive system, resulting in death, serious injury, or equipment damage.

- Ensure that permanent magnet motors are blocked to prevent unintended rotation.

⚠ WARNING**LEAKAGE CURRENT HAZARD (>3.5 mA)**

Leakage currents exceed 3.5 mA. Failure to ground the drive system properly can result in death or serious injury. Follow national and local codes regarding protective earthing of equipment with a leakage current >3.5 mA. Frequency converter technology implies high frequency switching at high power. This switching generates a leakage current in the ground connection. A fault current in the drive system at the output power terminals sometimes contain a DC component, which can charge the filter capacitors and cause a transient ground current. The ground leakage current depends on various system configurations including RFI filtering, shielded motor cables, and drive system power.

If the leakage current exceeds 3.5 mA, EN/IEC 61800-5-1 (Power Drive System Product Standard) requires special care.

Grounding must be reinforced in 1 of the following ways:

- Ensure the correct grounding of the equipment by a certified electrical installer.
- Ground wire of at least 10 mm² (6 AWG).
- Two separate ground wires, both complying with the dimensioning rules.

See EN 60364-5-54 § 543.7 for further information.

⚠ WARNING**EQUIPMENT HAZARD**

Contact with rotating shafts and electrical equipment can result in death or serious injury.

- Ensure that only trained and qualified personnel perform the installation.
- Ensure that electrical work conforms to national and local electrical codes.
- Follow the procedures in this document.

⚠ WARNING**DISCONNECT POWER BEFORE SERVICING**

Sometimes during installation, AC mains power is applied but then must be disconnected to change the line connections. Failure to follow these steps can result in death or serious injury.

- Disconnect the frequency converters from the AC mains, 230 V supply, and motor lines.
- After the lines have been disconnected, wait 20 minutes for the capacitors to discharge.

⚠ WARNING**HEAVY LOAD**

Unbalanced loads can fall and loads can tip over. Failure to take proper lifting precautions increases risk of death, serious injury, or equipment damage.

- Never walk under suspended loads.
- To guard against injury, wear personal protective equipment such as gloves, safety glasses, and safety shoes.
- Be sure to use lifting devices with the appropriate weight rating. The lifting bar must be able to handle the weight of the load.
- The load's center of gravity may be in an unexpected location. Failure to locate the center of gravity correctly, and position the load accordingly before lifting the load, can cause the unit to fall over or tilt unexpectedly during lifting and transport.
- The angle from the top of the drive module to the lifting cables has an impact on the maximum load force on the cable. This angle must be 65° or greater. Attach and dimension the lifting cables properly.

3 Product Overview

3.1 Intended Use

A frequency converter is an electronic motor controller that uses 1 or more drive modules to convert AC mains input into a variable AC waveform output. The frequency and voltage of the output are regulated to control the motor speed or torque. The frequency converter varies the motor speed based on system feedback, such as position sensors on a conveyor belt. The frequency converter also regulates the motor in response to remote commands from external controllers.

The VLT[®] Parallel Drive Modules basic kit described in this guide is UL 508 C compliant. The kit is used to create drive systems of 2 or 4 drive modules. These drive modules are based on the D4h frequency converter and can provide a greater power range in a smaller enclosure. The basic kit is designed to allow the flexibility to either order components through Danfoss or fabricate custom components.

The basic kit contains the following components:

- Drive modules
- Control shelf
- Wire harnesses
 - Ribbon cable with 44-pin connector (on both ends of the cable)
 - Relay cable with 16-pin connector (on 1 end of the cable)
 - DC fuse microswitch cable with 2-pin connectors (on 1 end of the cable)
- DC fuses
- Microswitches

Other components, such as bus bar kits and back-channel cooling duct kits, are available as options to customize the drive system.

NOTICE

EXTERNAL 230 V SUPPLY

An external 230 V supply is needed to power the SMPS (switch mode power supply) and any cabinet fans.

3.2 Drive Modules

Each drive module has an IP00 protection rating. Either 2 or 4 drive modules can be connected in parallel to create a drive system, based on power requirements.

3

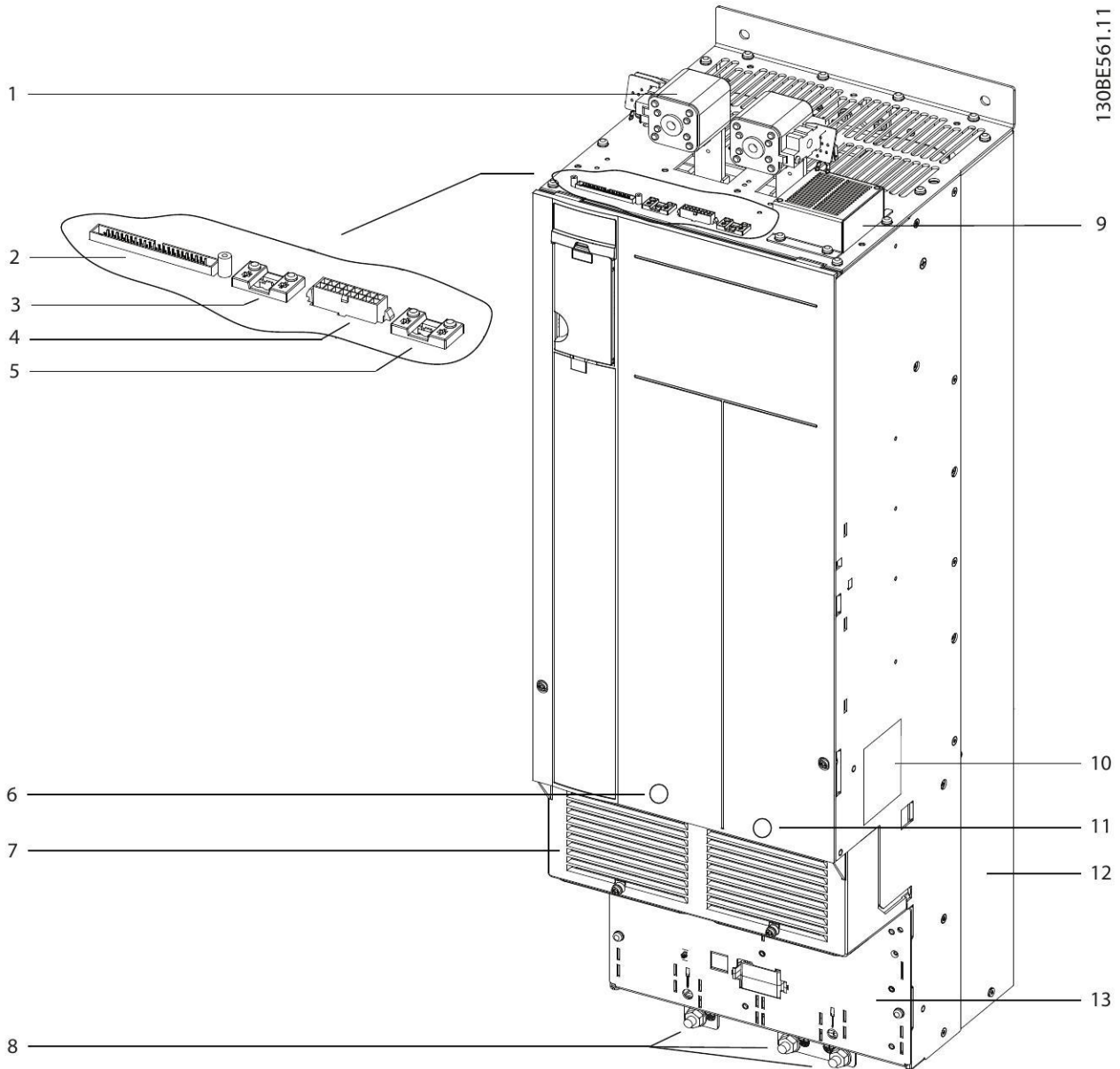

1	DC-link terminal and DC fuse	8	Ground terminals
2	MDCIC plug	9	Top fan
3	Microswitch to DC fuse	10	Drive module label. See <i>Illustration 4.2</i> .
4	Relays 1 and 2	11	Motor output terminals (inside the unit)
5	Brake fault jumper and connector	12	Heat sink and heat sink fan
6	Mains input terminals (inside the unit)	13	Ground plate
7	Terminal cover	-	-

Illustration 3.1 Drive Module Overview

3.3 Control Shelf

The control shelf contains the LCP, MDCIC, and control card. The LCP provides access to the system parameters. The MDCIC is connected to each of the drive modules via a ribbon cable and communicates to the control card. The control card controls the operation of the drive modules.

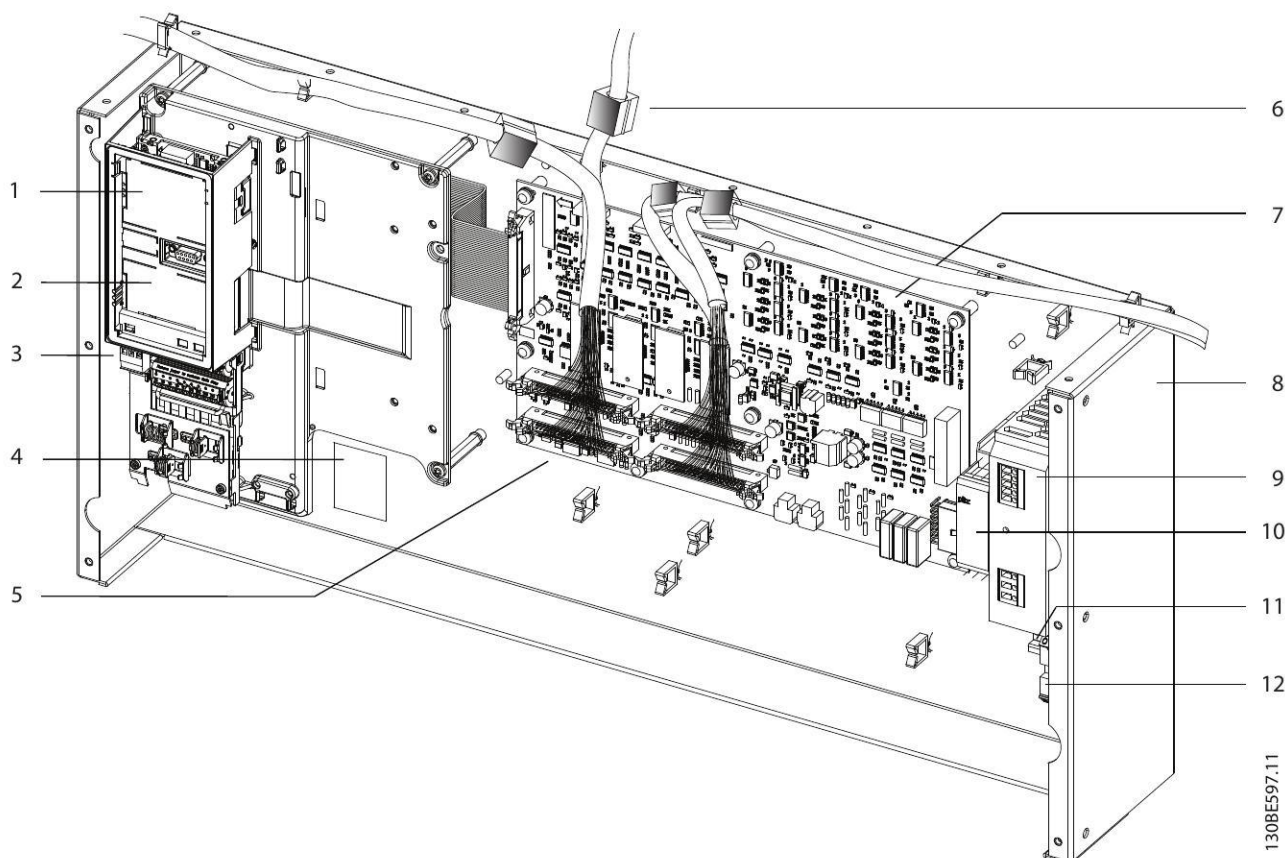

1308E597.11

1	LCP cradle	7	MDCIC card
2	Control card (underneath cover)	8	Control shelf
3	Control terminal blocks	9	Switch mode power supply (SMPS). Note that an external 230 V supply is needed to power the SMPS.
4	Top-level drive system label. See <i>Illustration 4.1</i> .	10	Pilz relay
5	44-pin cables from MDCIC board to drive modules	11	DIN rail
6	Ferrite core	12	Terminal block mounted on DIN rail

Illustration 3.2 Control Shelf

3.4 Wire Harness

The VLT® Parallel Drive Modules basic kit contains the following wire harnesses:

- Ribbon cable with 44-pin connector (on both ends of the cable)
- Relay cable with 16-pin connector (on 1 end of the cable)
- DC fuse microswitch cable with 2-pin connectors (on 1 end of the cable)

3.5 DC Fuses

The VLT® Parallel Drive Modules kit contains 2 DC fuses per drive module. These fuses on the supply side ensure that any damage is contained to inside the drive modules.

NOTICE

Use of fuses on the supply side is mandatory for IEC 60364 (CE) compliant installations.

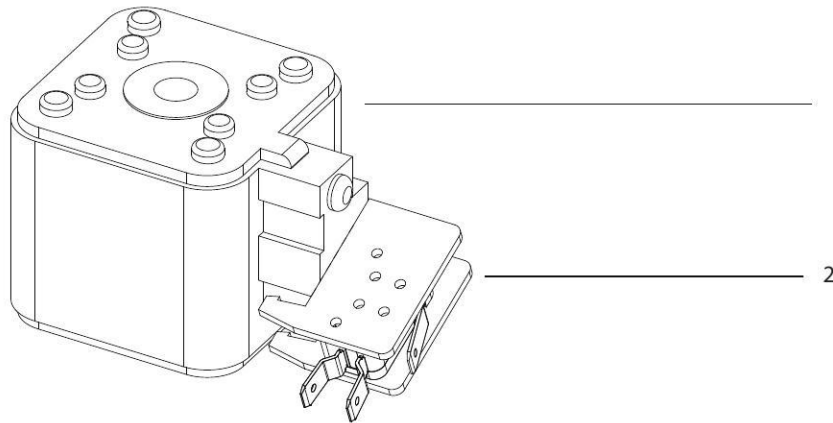

130BE750.10

1	DC fuse	2	Microswitch connector
---	---------	---	-----------------------

Illustration 3.3 DC Fuse and Microswitch Connector

4 Mechanical Installation

4.1 Receiving and Unpacking the Unit

4.1.1 Items Supplied

- Make sure that the items supplied and the information on the labels correspond to the order.
 - Top-level drive system. This label is found on the control shelf, lower right side of the LCP. See *Illustration 3.2*.
 - Drive module. This label is found inside the drive module enclosure, on the right side panel. See *Illustration 3.1*.
- Visually check the packaging and the VLT® Parallel Drive Modules components for damage caused by inappropriate handling during shipment. File any claim for damage with the carrier. Retain damaged parts, in case clarification is needed.

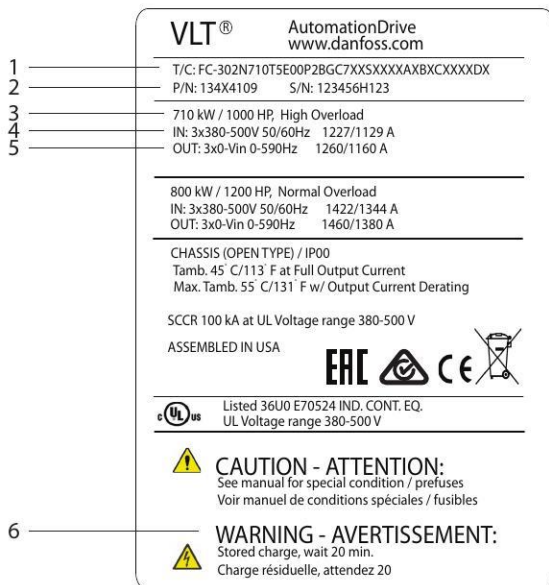

1	Type code
2	Code number
3	Power rating
4	Input voltage, frequency, and current
5	Output voltage, frequency, and current
6	Discharge time

Illustration 4.1 Top-level Drive System Label (Example)

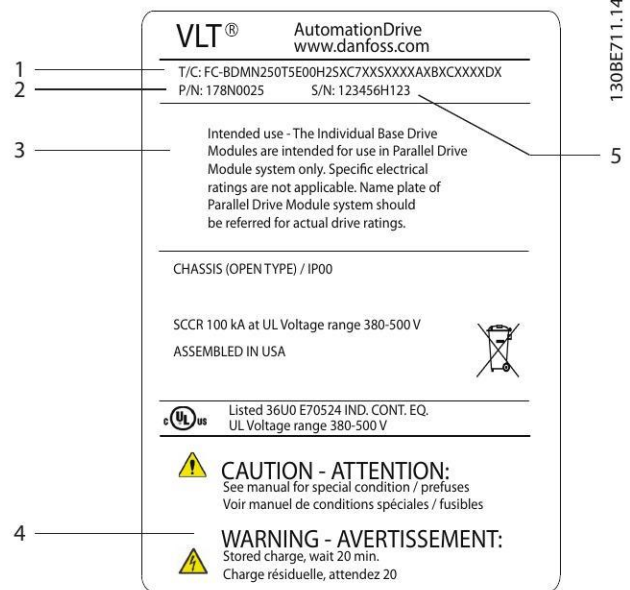

1	Type code
2	Code number
3	Intended use disclaimer
4	Discharge time
5	Serial number

Illustration 4.2 Drive Module Label (Example)

NOTICE

LOSS OF WARRANTY

Removing the labels from the VLT® Parallel Drive Modules can result in loss of warranty.

Receiving and unloading

- I-beam and hooks rated to lift a drive module having a weight of 125 kg (275 lb), with the necessary safety margins.
- Crane or other lifting aid rated to lift the minimum weight specified in the documentation package supplied with the drive module.
- Crowbar to disassemble the wooden shipping container.

Installation

- Drill with 10 mm or 12 mm drill bits.
- Tape measurer.
- Screwdriver.
- Wrench with relevant metric sockets (7–17 mm).
- Wrench extensions.
- Torx T50 tool.

Cabinet construction

Acquire the tools necessary for assembly of the panel - according to the design plans and established practices.

4.1.2 Lifting the Unit

For measurements and center of gravity, see *chapter 7.8 Kit Dimensions*.

- Ensure that the lifting device is suitable for the task.
- Move the unit using a hoist, crane, or forklift with the appropriate rating.
- Always use the dedicated lifting eye bolts. See *Illustration 4.3*.

⚠ CAUTION**HEAVY LOAD**

Unbalanced loads can fall and loads can tip over. Failure to take proper lifting precautions increases risk of death, serious injury, or equipment damage.

- Never walk under suspended loads.
- To guard against injury, wear personal protective equipment such as gloves, safety glasses, and safety shoes.
- Be sure to use lifting devices with the appropriate weight rating. The lifting bar must be able to handle the weight of the load.
- The load's center of gravity may be in an unexpected location. Failure to locate the center of gravity correctly and position the load accordingly before lifting the load can cause the unit to fall over or tilt unexpectedly during lifting and transport.
- The angle from the top of the drive module to the lifting cables has an impact on the maximum load force on the cable. This angle must be 65° or greater. Refer to *Illustration 4.3*. Attach and dimension the lifting cables properly.

4.1.3 Storage

Store the kit in a dry location. Keep the equipment sealed in its packaging until installation. Refer to *chapter 7.5 Ambient Conditions for Drive Modules* for recommended ambient conditions.

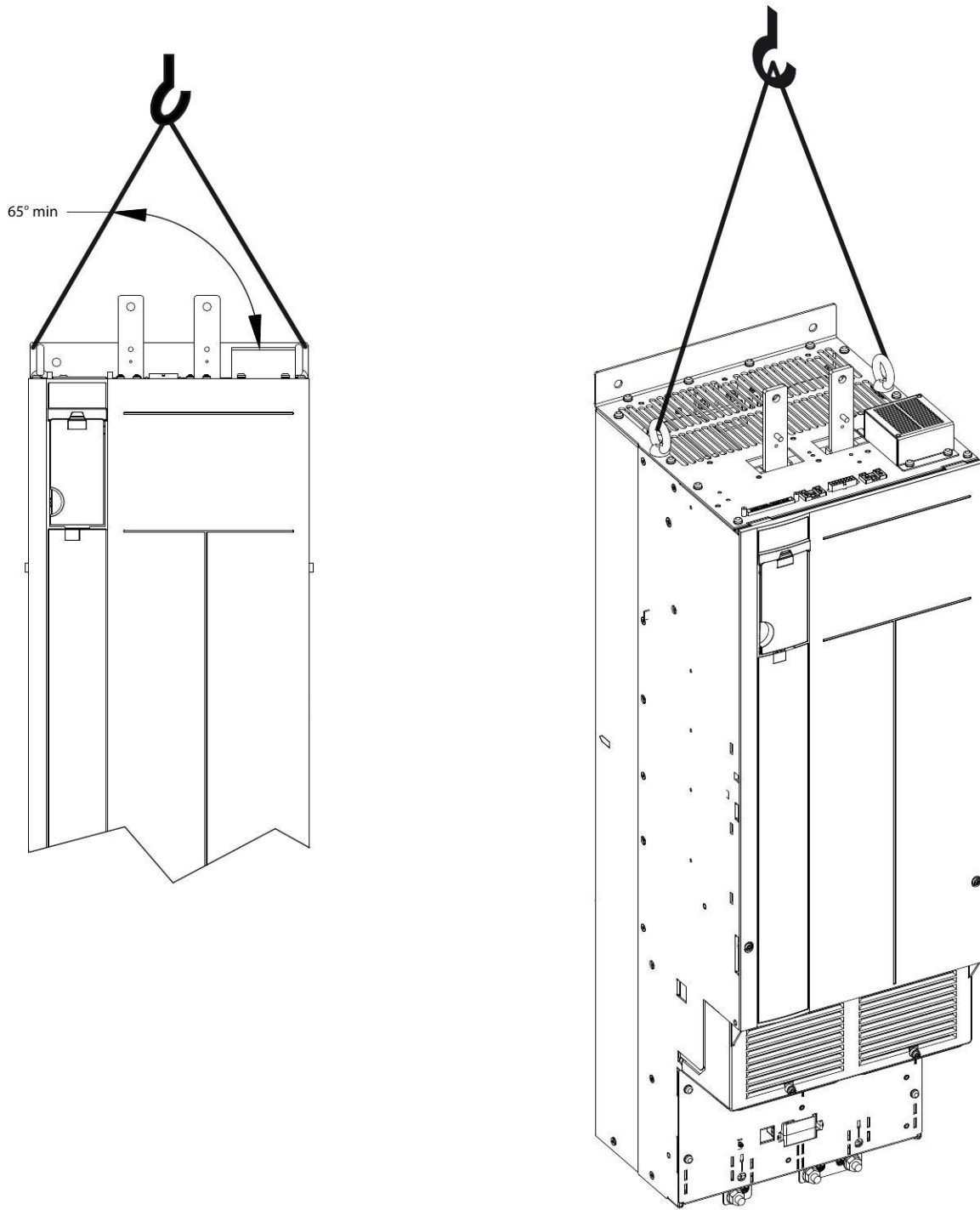

Illustration 4.3 Lifting the Drive Module

4.2 Requirements

This section describes the minimum recommended requirements for mechanical installation. For UL and CE requirements, see *chapter 5.2 Electrical Requirements for Certifications and Approvals*.

4.2.1 Environmental

Refer to for information on required operating temperature, humidity, and other environmental conditions.

4.2.2 Cabinet

The kit consists of either 2 or 4 drive modules, depending on the power rating. The cabinets have to meet the following minimum requirements:

Width [mm (in)]	2-drive: 800 (31.5), 4-drive: 1600 (63)
Depth [mm (in)]	600 (23.6)
Height [mm (in)]	2000 (78.7) ¹⁾
Weight capacity [kg (lb)]	2-drive: 450 (992), 4-drive: 910 (2006)
Ventilation openings	See <i>chapter 4.2.5 Cooling and Airflow Requirements</i> .

Table 4.1 Cabinet Requirements

1) Required if Danfoss busbar or cooling kits are used.

NOTICE

EXTERNAL 230 V SUPPLY

An external 230 V supply is required for the SMPS (switch mode power supply). Danfoss recommends using a 6 A, 10 A, or 16 A slow-blow fuse when installing the external supply.

4.2.3 Busbars

If the Danfoss busbar kit is not used, see *Table 4.2* for the cross-section measurements that are required when creating customized busbars. For terminal dimensions, refer to *chapter 7.8.2 Terminal Dimensions* and *chapter 7.8.3 DC Bus Dimensions*.

Description	Width [mm (in)]	Thickness [mm (in)]
AC motor	143.6 (5.7)	6.4 (0.25)
AC mains	143.6 (5.7)	6.4 (0.25)
DC bus	76.2 (3.0)	12.7 (0.50)

Table 4.2 Cross-section Measurements for Customized Busbars

NOTICE

Align busbars vertically to provide maximum airflow.

4.2.4 Thermal Considerations

For heat dissipation values, refer to *chapter 7.1 Power-dependent Specifications*. The following heat sources must be considered when determining cooling requirements:

- Ambient temperature outside enclosure.
- Filters (for example, sine-wave and RF).
- Fuses.
- Control components.

For required cooling air, refer to *chapter 4.2.5 Cooling and Airflow Requirements*.

4.2.5 Cooling and Airflow Requirements

The recommendations provided in this section are necessary for effective cooling of the drive modules within the panel enclosure. Each drive module contains a heat sink fan and a mixing fan. Typical enclosure designs utilize door fans along with the drive module fans to remove waste heat from the enclosure.

Danfoss provides several back-channel cooling kits as options. These kits remove 85% of the waste heat from the enclosure, reducing the need for large door fans.

NOTICE

Make sure that the total flow of the cabinet fans meets the recommended airflow.

Drive module cooling fans

The drive module is equipped with a heat sink fan, which provides the required flow rate of 840 m³/h (500 cfm) across the heat sink. Also, there is a cooling fan mounted on the top of the unit, and a small 24 V DC mixing fan mounted under the input plate that operates any time the drive module is powered on.

In each drive module, the power card provides DC voltage to power the fans. The mixing fan is powered by 24 V DC from the main switch mode power supply. The heat sink fan and the top fan are powered by 48 V DC from a dedicated switch mode power supply on the power card. Each fan has a tachometer feedback to the control card to confirm that the fan is operating correctly. On/off and speed control of the fans help reduce unnecessary acoustical noise and extend the life of the fans.

Cabinet fans

When the back-channel option is not used, fans mounted in the cabinet must remove all the heat generated inside the enclosure.

For each enclosure housing 2 drive module, the cabinet fan flow recommendation is as follows:

- When back-channel cooling is used, 680 m³/h (400 cfm) flow is recommended.
- When back-channel cooling is not used, 4080 m³/h (2400 cfm) flow is recommended.

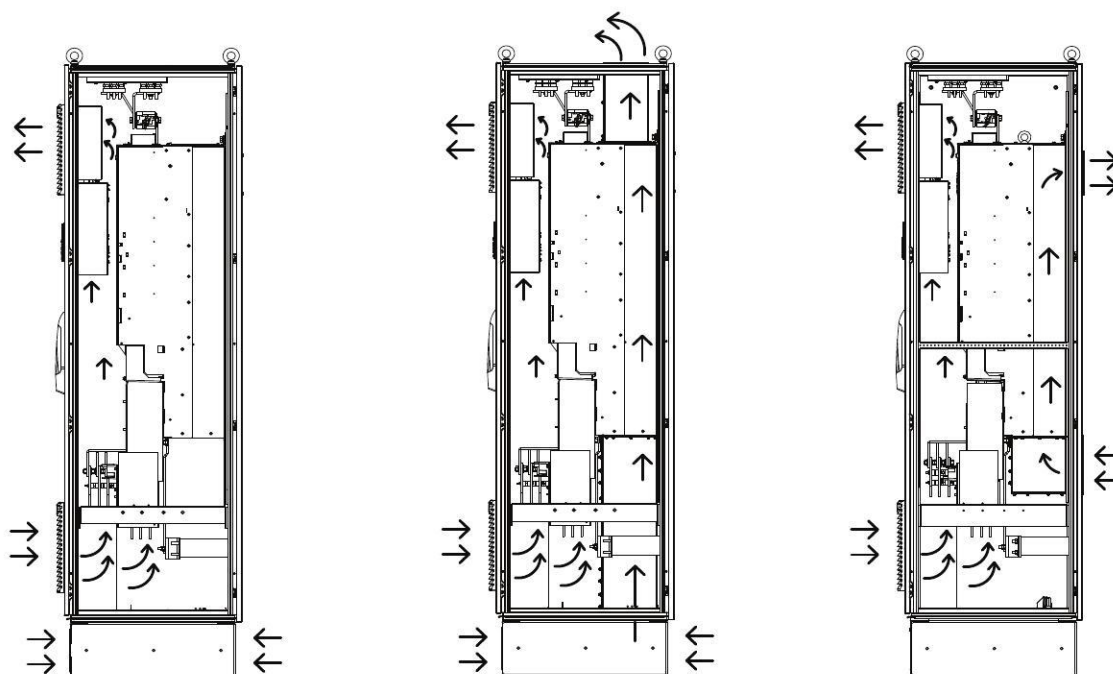

Illustration 4.4 Airflow, Standard Unit (Left), Bottom/Top Cooling Kit (Middle), and Back/Back Cooling Kit (Right)

4.3 Installing the Drive Modules

Install the drive modules into the cabinet frame as described in the following steps.

1. Unpack the drive modules from the packaging. See *chapter 4.1 Receiving and Unpacking the Unit*.
2. Install 2 eye bolts in the top of the first drive module. Prepare the drive module for lifting, using an appropriate lifting harness and an overhead hoist or crane with the necessary lifting capacity. See *chapter 4.1.2 Lifting the Unit*.

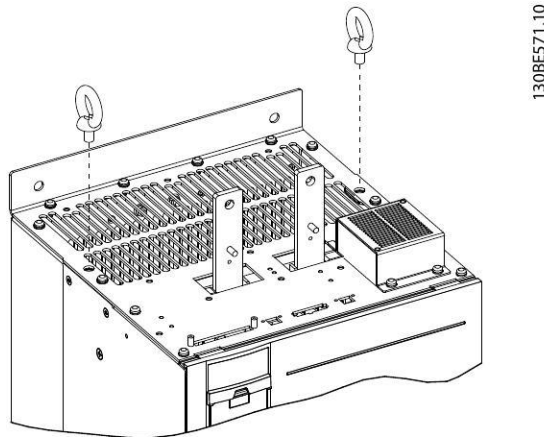
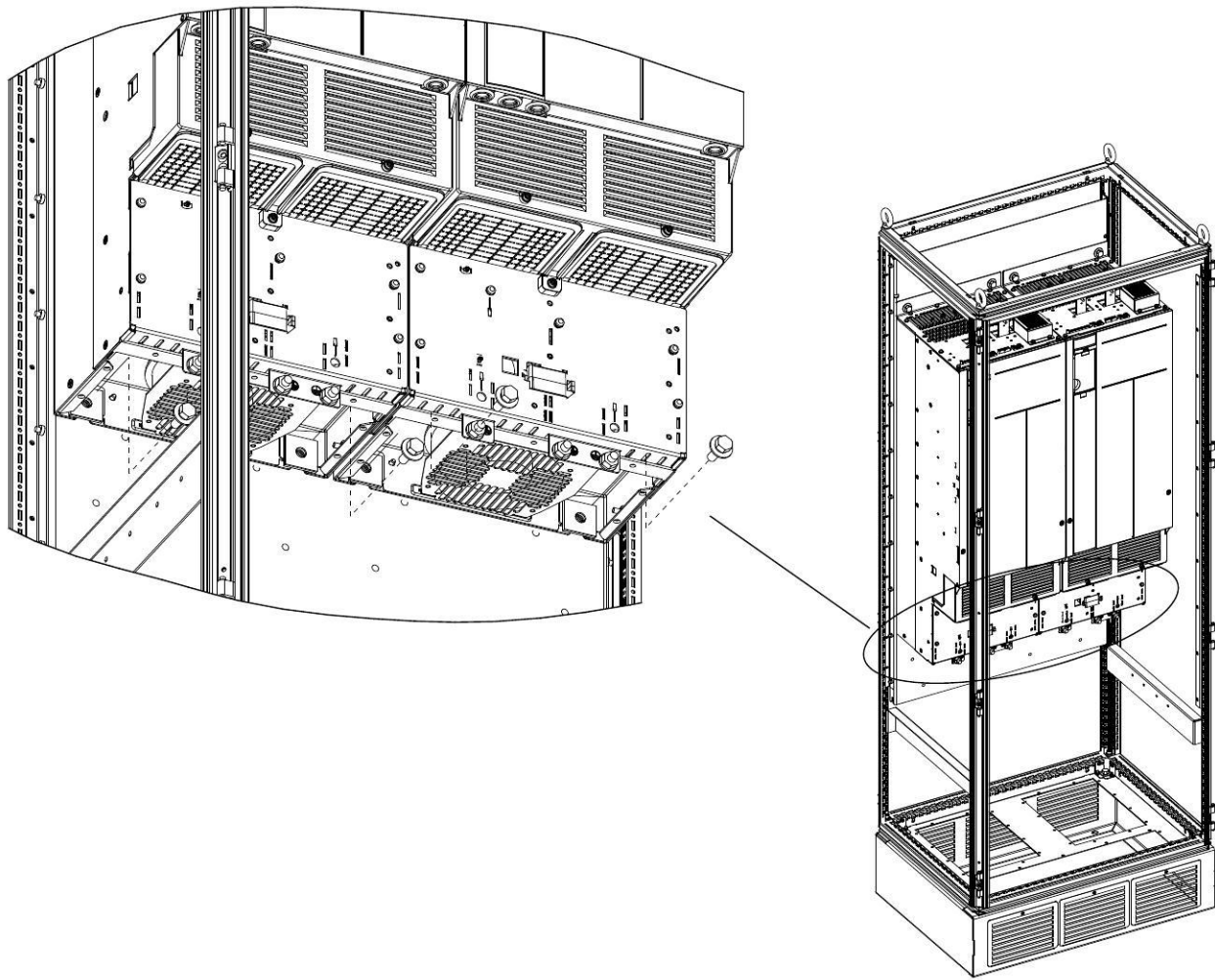

Illustration 4.5 Installation of Eye Bolts

3. Install the 2 bottom mounting screws and gaskets onto the mounting panel.
4. Using the crane or hoist, lift the drive module and then lower the unit through the top of the cabinet frame. Align the bottom mounting holes of the unit with the 2 bottom mounting screws on the mounting panel.
5. Verify that the drive module is correctly aligned on the mounting panel and then secure the bottom of the unit to the panel with the 2 hex nuts. See *Illustration 4.6*. Torque the hex nuts. Refer to *chapter 7.9 Fastener Tightening Torques*.
6. Secure the top of the unit to the mounting panel with M10x26 screws, and then torque the screws.
7. Line up the groove on the microswitch with the edges on each DC fuse and press firmly until the microswitch clicks into place.
8. Install 2 DC fuses with microswitches onto the tops of the DC-link terminals on each drive module. The microswitches should be installed on the outer side of each terminal. Refer to *Illustration 3.1*.
9. Secure each fuse with 2 M10 screws and torque the screws.
10. Install the next drive module.



130BE572.10

Illustration 4.6 Installation of Bottom Mounting Bolts

4.4 Installing the Control Shelf

NOTICE

To avoid RFI, do not route control wiring together with power cables or bus bars.

1. Remove the control shelf assembly from its package.
2. Remove the LCP from the control shelf.
3. Use some type of mounting bracket to install the control shelf. Danfoss does not supply the mounting brackets for the control shelf. For EMC-correct installation, refer to *Illustration 4.7*.
4. Remove the MDCIC cover from the control shelf assembly.
5. Connect the 44-pin ribbon cables from the MDCIC card to the top of the drive modules, following the sequence numbers indicated next to the connectors on the MDCIC.
6. Route the 44-pin ribbon cables inside the cabinet.
7. Connect the external brake fault wiring harness between the microswitch terminals and the brake jumper connector on the top of the drive module.
8. Connect the relay wiring between relay 1 or 2 on the control shelf and the corresponding relay connector on the top of the drive module.
9. Connect the microswitch to the microswitch connector provided on the top of the drive module. Refer to *Illustration 3.1* and *Illustration 3.3*.

4

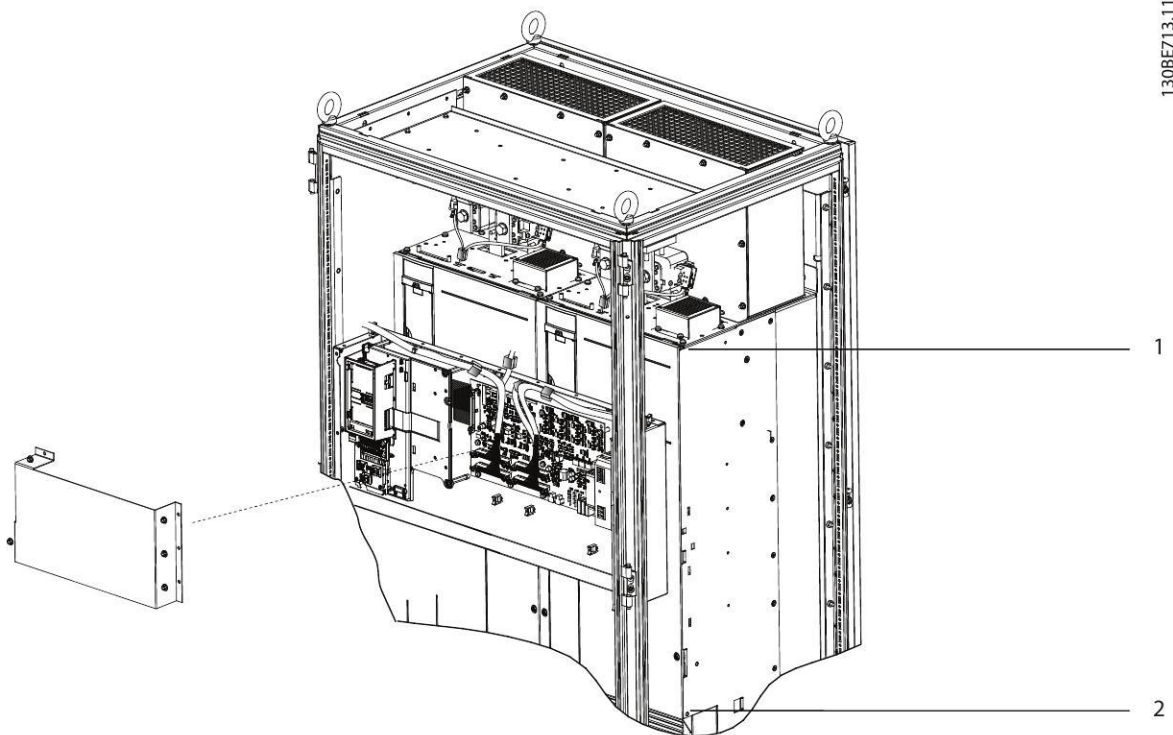

130BE713.11

1	Control shelf must stay below this point	2	Control shelf must stay above this point
---	------------------------------------------	---	------------------------------------------

Illustration 4.7 Positioning the Control Shelf for EMC-correct Installation

5 Electrical Installation

5.1 Safety Instructions

See *chapter 2 Safety* for general safety instructions.

WARNING

INDUCED VOLTAGE

When output motor cables from different frequency converters are run together, induced voltage can charge equipment capacitors even with the equipment turned off and locked out.

To avoid death or serious injury:

- Run output motor cables separately or use shielded cables.
- Simultaneously lock out all the frequency converters.

CAUTION

SHOCK HAZARD

The drive system can cause a DC current in the protective earth (PE) conductor.

- When a residual current-operated protective device (RCD) is used for protection against electrical shock, only an RCD of Type B is allowed on the supply side.

Failure to follow this recommendation could prevent the RCD from providing the intended protection.

NOTICE

MOTOR OVERLOAD PROTECTION

The drive modules are supplied with Class 20 overload protection for single motor applications.

Overcurrent protection

- Extra protective equipment, such as short-circuit protection or motor thermal protection between the drive modules and the motors, is required for applications with multiple motors.
- The correct input fusing is required to acquire approvals and meet certification requirements, and to provide short circuit and overcurrent protection. These fuses are not factory-supplied, and must be provided by the installer. See maximum fuse ratings in *chapter 7.1 Power-dependent Specifications*.

Wire type and ratings

- All wiring must comply with local and national regulations regarding cross-section and ambient temperature requirements.
- Power connection wire recommendation: minimum 75 °C rated copper wire.

See *chapter 7.6 Cable Specifications* for recommended wire sizes and types.

CAUTION

PROPERTY DAMAGE

Electronic thermal relay (ETR) protection against motor overload is not included in the default setting. To program the LCP for this function, refer to the *VLT® Parallel Drive Modules User Guide*.

5.2 Electrical Requirements for Certifications and Approvals

The standard configuration provided in this guide (drive modules, control shelf, wire harnesses, fuses, and microswitches) is UL and CE certified. The following conditions must be met apart from the standard configuration to obtain UL and CE regulatory approval requirements. For a list of disclaimers, see *chapter 8.1 Disclaimer*.

- Use the frequency converter in a heated, indoor-controlled environment. Cooling air must be clean, free from corrosive materials, and electrically conductive dust. See for specific limits.
- Maximum ambient air temperature is 40 °C (104 °F) at rated current.
- The drive system must be assembled in clean air, according to enclosure classification. To obtain UL or CE certification regulatory approvals, drive modules must be installed according to the standard configuration provided in this guide.
- Maximum voltage and current must not exceed the values provided in *chapter 7.1 Power-dependent Specifications* for the specified drive configuration.
- The drive modules are suitable for use on a circuit capable of delivering not more than 100 kA rms symmetrical amperes at the drive nominal voltage (600 V maximum for 690 V units) when protected by fuses with the standard configuration. Refer to *chapter 5.4.1 Fuse Selection*. The ampere rating is based on tests done according to UL 508C.
- The cables located within the motor circuit must be rated for at least 75 °C (167 °F) in UL-compliant installations. The cable sizes have been provided in *chapter 7.1 Power-dependent Specifications* for the specified drive configuration.
- The input cable must be protected with fuses. Circuit breakers must not be used without fuses in the U.S. Suitable IEC (class aR) fuses and UL (class L or T) fuses are listed in *chapter 5.4.1 Fuse Selection*. In addition, country-specific regulatory requirements must be adhered to.
- For installation in the U.S., branch circuit protection must be provided according to the National Electrical Code (NEC) and any applicable local codes. To fulfill this requirement, use UL-classified fuses.
- For installation in Canada, branch circuit protection must be provided according to the Canadian Electrical Code and any applicable provincial codes. To fulfill this requirement, use the UL-classified fuses.

5.4 Fuses

5.4.1 Fuse Selection

To protect the drive system in case 1 or more internal components break down within a drive module, use fuses and/or circuit breakers at the mains supply side.

5.4.1.1 Branch Circuit Protection

To protect the installation against electrical and fire hazards, protect all branch circuits in an installation against short circuit and overcurrent according to national and international regulations.

5.4.1.2 Short-circuit Protection

Danfoss recommends the fuses listed in *chapter 5.4.1.3 Recommended Fuses for CE Compliance* and *chapter 5.4.1.4 Recommended Fuses for UL Compliance* to achieve CE or UL Compliance in the protection of service personnel and property against the consequences of component breakdown in the drive modules.

5.4.1.3 Recommended Fuses for CE Compliance

Number of drive modules	FC 302	FC 102/FC 202	Recommended fuse (maximum)
2	N450	N500	aR-1600
4	N500	N560	aR-2000
4	N560	N630	aR-2000
4	N630	N710	aR-2500
4	N710	N800	aR-2500
4	N800	N1M0	aR-2500

Table 5.1 6-Pulse Drive Systems (380–500 V AC)

Number of drive modules	FC 302	FC 102/FC 202	Recommended fuse (maximum)
2	N250	N315	aR-630
2	N315	N355	aR-630
2	N355	N400	aR-630
2	N400	N450	aR-800
2	N450	N500	aR-800
4	N500	N560	aR-900
4	N560	N630	aR-900
4	N630	N710	aR-1600
4	N710	N800	aR-1600
4	N800	N1M0	aR-1600

Table 5.2 12-Pulse Drive Systems (380–500 V AC)

Number of drive modules	FC 302	FC 102/FC 202	Recommended fuse (maximum)
4	N630	N710	aR-1600
4	N710	N800	aR-2000
4	N800	N900	aR-2500
4	N900	N1M0	aR-2500
4	N1M0	N1M2	aR-2500

Table 5.3 6-Pulse Drive Systems (525–690 V AC)

Number of drive modules	FC 302	FC 102/FC 202	Recommended fuse (maximum)
2	N250	N315	aR-550
2	N315	N355	aR-630
2	N355	N400	aR-630
2	N400	N500	aR-630
2	N500	N560	aR-630
2	N560	N630	aR-900
4	N630	N710	aR-900
4	N710	N800	aR-900
4	N800	N900	aR-900
4	N900	N1M0	aR-1600
4	N1M0	N1M2	aR-1600

Table 5.4 12-Pulse Drive Systems (525–690 V AC)

5.4.1.4 Recommended Fuses for UL Compliance

- The drive modules are supplied with built-in AC fuses. The modules have been qualified for 100 kA short-circuit current rating (SCCR) for the standard busbar configurations at all voltages (380–690 V AC).
- If no power options or extra busbars are connected externally, the drive system is qualified for 100 kA SCCR with any Class L or Class T UL-listed fuses connected at the input terminals of the drive modules.
- Do not exceed the listed fuse rating in *Table 5.6* to *Table 5.7* with the current rating of the Class L or Class T fuses.

Number of drive modules	FC 302	FC 102/FC 202	Recommended fuse (maximum)
2	N450	N500	1600 A
4	N500	N560	2000 A
4	N560	N630	2000 A
4	N630	N710	2500 A
4	N710	N800	2500 A
4	N800	N1M0	2500 A

Table 5.5 6-Pulse Drive Systems (380–500 V AC)

Number of drive modules	FC 302	FC 102/ FC 202	Recommended fuse (maximum)
2	N250	N315	630 A
2	N315	N355	630 A
2	N355	N400	630 A
2	N400	N450	800 A
2	N450	N500	800 A
4	N500	N560	900 A
4	N560	N630	900 A
4	N630	N710	1600 A
4	N710	N800	1600 A
4	N800	N1M0	1600 A

Table 5.6 12-Pulse Drive Systems (380–500 V AC)

Any minimum 500 V UL-listed fuse can be used for the 380–500 V AC drive systems.

Number of drive modules	FC 302	FC 102/ FC 202	Recommended fuse (maximum)
4	N630	N710	1600 A
4	N710	N800	2000 A
4	N800	N900	2500 A
4	N900	N1M0	2500 A
4	N1M0	N1M2	2500 A

Table 5.7 6-Pulse Drive Systems (525–690 V AC)

Number of drive modules	FC 302	FC 102/ FC 202	Recommended fuse (maximum)
2	N250	N315	550 A
2	N315	N355	630 A
2	N355	N400	630 A
2	N400	N500	630 A
2	N500	N560	630 A
2	N560	N630	900 A
4	N630	N710	900 A
4	N710	N800	900 A
4	N800	N900	900 A
4	N900	N1M0	1600 A
4	N1M0	N1M2	1600 A

Table 5.8 12-Pulse Drive Systems (525–690 V AC)

Any minimum 700 V UL-listed fuse can be used for the 525–690 V AC drive systems.

5.5 Electrical Kit Installation

This section describes how the electrical kit is used to connect 2 or 4 drive modules in parallel - to provide controlled power to an AC motor. A diagram is provided for each of the 4 configurations which, if followed, meet specific agency approvals and certifications. If designing and building other configurations, seek agency approvals or certifications apart from Danfoss.

Read this section for guidance in making electrical connections when assembling the drive modules into a panel.

5.6 DC Bus Fuse Installation

DC fuses are provided in the basic kit. Install the DC fuses at the available DC terminals at individual drive modules, using the recommended bolts. Each DC fuse has a fixture for mounting the microswitches, which are used to detect a fuse failure. See *Illustration 3.3*. Install the supplied harness between the microswitch terminals and the brake fault jumper port on the top of the drive modules. If the jumper is not installed properly, the unit does not power up and the error *Brake IGBT Fault* is shown. The microswitch has 3 terminals: NO, NC, and COM. Connect the wire harness between the NC and COM terminals. If it is connected between any other terminals, the unit does not power up, and the error *Brake IGBT Fault* is shown.

NOTICE

The microswitch is a snap fit onto the fuse. Ensure that the switch is properly installed on the fuses.

5.7 Motor Connections

5.7.1 Motor Cables

See *chapter 7.6 Cable Specifications* for more information on wire type and sizes.

NOTICE

SHIELDED CABLE LENGTH

With a standard VLT® Parallel Drive Modules drive system, shielded cables up to 150 m (492 ft) long or unshielded up to 300 m (984 ft) long provide full voltage at the motor. If this cable length is exceeded, use a dU/dt filter. For information on the selection of a dU/dt filter, refer to the *VLT® Parallel Drive Modules Design Guide*.

5.7.1.1 Voltage Rating

Peak voltages up to 2.8 times the mains voltage of the VLT® Parallel Drive Modules drive system can occur in the motor cable. High peak voltages can severely stress the

motor cable. Use motor cables with rated voltage specification of at least 0.6/1 kV. Cables in this range provide good resistance to insulation breakdown.

5.7.1.2 Dimensions

Follow local codes for current capacity data for cables and conductors. Widely used codes include: NFPA 70, EN 60204-1, VDE 0113-1, and VDE 0298-4. Overdimensioning for harmonics is not required.

5.7.1.3 Length

Keep cables as short as possible. Voltage drop and heat dissipation depends on the frequency and is approximately proportional to cable length. Consult the cable manufacturer specifications regarding the length and expected voltage drop when connected to the drive system. See *chapter 7.6 Cable Specifications*.

5.7.1.4 Shielding

The following factors are important for effective shielding:

- Make sure that the amount of cable surface covered by the shield is at least 80%.
- Use a single-layer braided copper shield. Ensure that the shield is braided to reduce surface area for leakage currents.
- Use cables with double shielding to improve the attenuation of interference further. Twisted conductors reduce magnetic fields.
- Use cables that are shielded at both ends between the drive system and the motor.
- To comply with radio frequency interference limits, shield the cables between the drive system and the motor at both ends.
- Ensure that the shield fully surrounds the cable.
- Route cable glands or cable clamps directly to the grounding point.
- Keep connections as short as possible at each end of the cable.
- Bridge shield gaps such as terminals, switches, or contactors by using connections with the lowest possible impedance and the largest possible surface area.

NOTICE

TWISTED SHIELD ENDS (PIGTAILS)

Twisted shield ends increase the shield impedance at higher frequencies, which reduces the shield effect and increases the leakage current. To avoid twisted shield ends, use integrated shield clamps. Refer to *Illustration 5.2*.

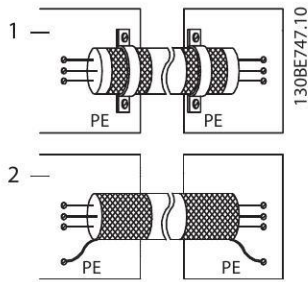

- | | |
|---|---------------------------------------------------------|
| 1 | Correct grounding of shielded ends |
| 2 | Incorrect grounding using twisted shield ends (pigtail) |

Illustration 5.2 Example of Shield Ends

5.7.2 Types of Thermal Protection

5.7.2.1 PTC Thermistor

Using a digital input and 10 V supply

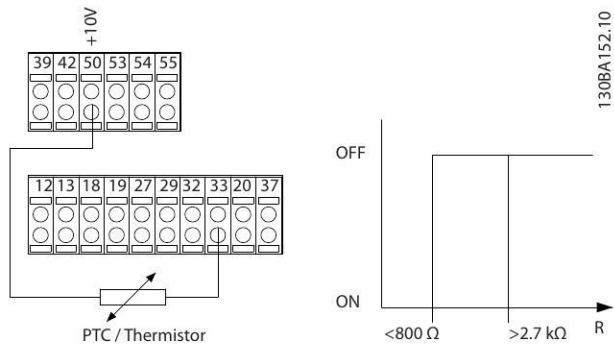

Illustration 5.3 PTC Thermistor Connection - Digital Input with 10 V Supply

Using an analog input and 10 V supply

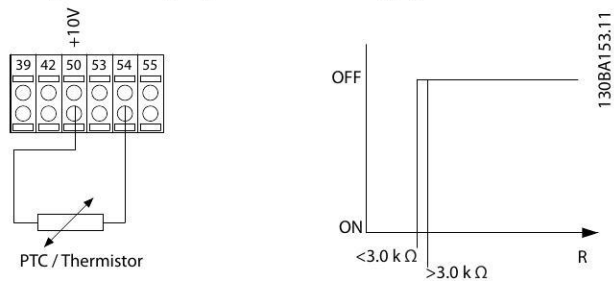

Illustration 5.4 PTC Thermistor Connection - Analog Input with 10 V Supply

Using a digital input and 24 V as supply

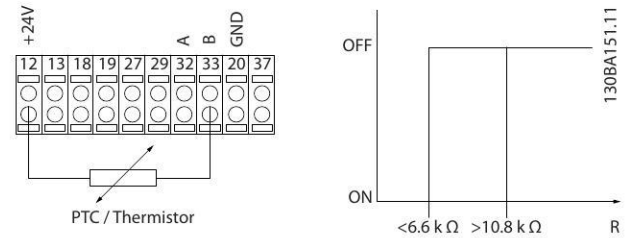

Illustration 5.5 PTC Thermistor Connection - Digital Input with 24 V Supply

Check that the selected supply voltage follows the specification of the used thermistor element.

Input digital/ analog	Supply voltage [V]	Trip resistance k Ω	Reset resistance
Digital	10	>2.7	<800 Ω
Analog	10	>3.0	<3.0 k Ω
Digital	24	>10.8	<6.6 k Ω

Table 5.9 PTC Thermistor Resistance Parameters

5

5.7.2.2 KTY Sensor

The frequency converter handles 3 types of KTY sensors:

- KTY Sensor 1: 1 kΩ at 100 °C (212 °F). Philips KTY 84-1 is an example.
- KTY Sensor 2: 1 kΩ at 25 °C (77 °F). Philips KTY 83-1 is an example.
- KTY Sensor 3: 1 kΩ at 25 °C (77 °F). Philips KTY-10 is an example.

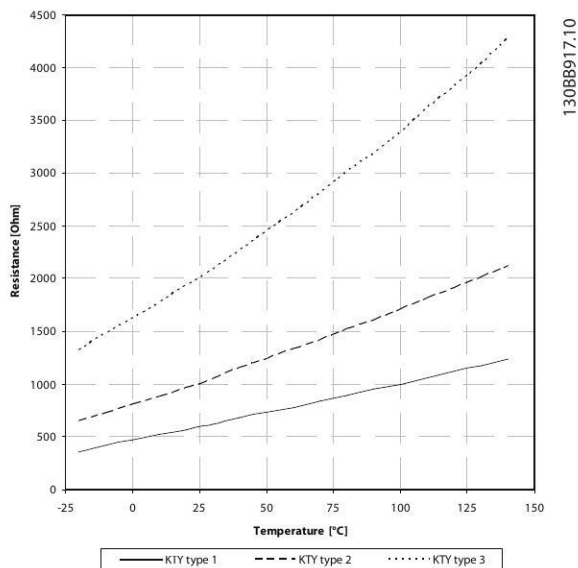

Illustration 5.6 KTY Type Selection

NOTICE

PELV COMPLIANCE

If short circuits occur between motor windings and the sensor, PELV compliance is not achieved when the motor temperature is monitored via a thermistor or KTY sensor. Ensure that the sensor is isolated better.

5.7.2.3 Brake Resistor Thermal Switch Installation

Each drive module has a brake fault jumper connector on the top plate, which is used to connect the Klixon thermal switch on the brake resistors. This connector has a pre-installed jumper as shown in *Illustration 8.3*. The brake fault jumper must always be in place to ensure proper operation of the drive module. Without this jumper connection, the drive module does not allow the inverter to operate, and a brake IGBT fault is shown.

The thermal switch is a normally-closed type. If the brake resistor temperature exceeds recommended values, the thermal switch opens. Use 1 mm² (18 AWG), reinforced and doubly insulated wire for the connection. See *Illustration 8.5*.

NOTICE

Danfoss is not responsible for the failure of any Klixon thermal switch.

5.7.3 Motor Terminal Connections

WARNING

INDUCED VOLTAGE

Induced voltage from output motor cables from different frequency converters that are run together can charge equipment capacitors even with the equipment turned off and locked out. Failure to run output motor cables separately or use shielded cables could result in death or serious injury.

- Run output motor cables separately.

Or

- Use shielded cables.
- Simultaneously lock out all the frequency converters.
- Comply with local and national electrical codes for cable sizes. For maximum cable sizes, see *chapter 7.1 Power-dependent Specifications*.
- Follow motor manufacturer wiring requirements.
- Do not wire a starting or pole-changing device (for example, Dahlander motor or slip ring induction motor) between the drive system and the motor.

5.7.3.1 Motor Cable

All types of 3-phase asynchronous standard motors can be used with the drive system.

Connect the motor to the following terminals:

- U/T1/96
- V/T2/97
- W/T3/98
- Ground to terminal 99

Factory setting is for clockwise rotation with the drive system output connected as follows:

Terminal number	Function
96	Mains U/T1
97	V/T2
98	W/T3
99	Ground

Table 5.10 Motor Cable Terminals

Changing motor rotation

- Terminal U/T1/96 connected to U-phase
- Terminal V/T2/97 connected to V-phase
- Terminal W/T3/98 connected to W-phase

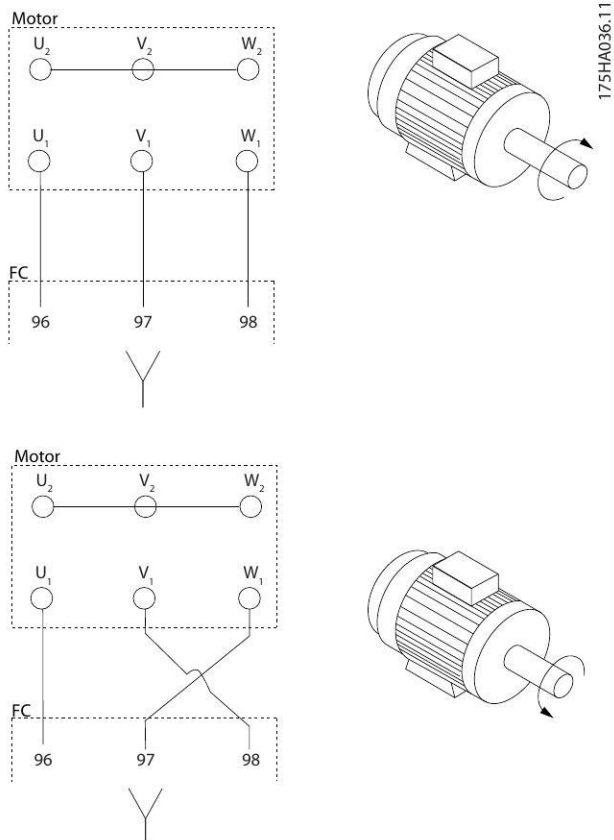

Illustration 5.7 Changing Motor Rotation

The direction of rotation can be changed by switching 2 phases in the motor cable, or by changing the setting of *parameter 4-10 Motor Speed Direction*.

Motor rotation check can be performed using *parameter 1-28 Motor Rotation Check* and following the steps shown in *Illustration 5.7*.

5.7.3.2 Motor Terminal Connections in 2-Drive Module Systems

Illustration 8.9 and *Illustration 8.10* show the bus bar connections for 6-pulse and 12-pulse 2-drive systems, respectively. If a common terminal design is used, there is 1 set of motor terminals.

NOTICE

MULTIPLE MOTOR CABLES

If connecting more than 1 set of motor terminals, use the same number, size, and length of cables for each set of terminals. For example, do not use 1 cable on one motor terminal and 2 cables on another motor terminal.

1. Measure between the common terminals and the first common point of a phase, typically the motor terminals.
2. Strip a section of the outer cable insulation.
3. Connect the ground wire to the nearest protective earth terminal.
4. Connect the 3-phase motor wiring to terminals U/96, V/97, and W/98 using M10 screws.
5. Tighten the motor terminals. See *chapter 7.9.1 Tightening Torques for Terminals*.

5.7.3.3 Motor Terminal Connections in 4-Drive Module Systems

Illustration 8.11 shows the bus bar connections for a 4-drive system. If a common terminal design is used, there is 1 set of motor terminals in each cabinet.

NOTICE

MULTIPLE MOTOR CABLES

If connecting more than 1 set of motor terminals, use the same number, size, and length of cables for each set of terminals. For example, do not use 1 cable on one motor terminal and 2 cables on another motor terminal.

1. Measure between the common terminals and the first common point of a phase, typically the motor terminals.
2. Strip a section of the outer cable insulation.
3. Connect the ground wire to the nearest protective earth (ground) terminal.
4. Connect the 3-phase motor wiring to terminals U/96, V/97, and W/98 using M10 screws.
5. Tighten the motor terminals. See *chapter 7.9.1 Tightening Torques for Terminals*.

5.8 Mains Connections

There are several types of AC mains systems for supplying power to frequency converters. Each affects the EMC characteristics of the system. The 5-wire TN-S systems are regarded as best regarding EMC, while the isolated IT system is the least preferred.

System type	Description
TN mains systems	There are 2 types of TN mains distribution systems: TN-S and TN-C.
TN-S	A 5-wire system with separate neutral (N) and protective earth (PE) conductors. It provides the best EMC properties and avoids transmitting interference.
TN-C	A 4-wire system with a common neutral and protective earth (PE) conductor throughout the system. The combined neutral and PE conductor results in poor EMC characteristics.
TT mains systems	A 4-wire system with a grounded neutral conductor and individual grounding of the drive system. It has good EMC characteristics when grounded properly.
IT grid system	An isolated 4-wire system with the neutral conductor either not grounded or grounded via an impedance.

Table 5.11 AC Mains Systems and EMC Characteristics

5.8.1 AC Mains Terminal Connections

When making mains connections, observe the following:

- Size the wiring based on the input current of the frequency converter. For maximum wire sizes, see *chapter 7.1 Power-dependent Specifications*.
- Comply with local and national electrical codes for cable sizes.

5.8.1.1 Mains Terminal Connections in 2-Drive Module Systems

Illustration 8.9 and *Illustration 8.10* show the bus bar connections for 6-pulse and 12-pulse 2-drive systems, respectively.

- If a common terminal design is used with a 6-pulse, 2-drive system, there is 1 set of mains terminals.
- Common terminal design cannot be used with 12-pulse mains connections in a 2-drive module systems. The mains cables are connected directly to the drive input terminals.
- There are individual brake terminals available in each drive module. Connect an equal number of recommended cables to the individual brake terminals.

NOTICE

MULTIPLE MAINS CABLES

If connecting more than 1 set of mains terminals, use the same number, size, and length of cables for each set of terminals. For example, do not use 1 cable on one mains terminal and 2 cables on another mains terminal.

1. Measure between the common terminals and the first common point of a phase, typically the mains terminals.
2. For 12-pulse drive modules, the set of cables from the 1st drive module connects to the star-secondary winding of the 12-pulse transformer. The set from the 2nd drive module connects to the delta-secondary winding of the 12-pulse transformer.
3. Strip a section of the outer cable insulation.
4. Connect the ground wire to the nearest ground terminal.
5. Connect the 3-phase mains wiring to terminals R/91, S/92, and T/93 using M10 screws.
6. Tighten the mains terminals. See *chapter 7.9.1 Tightening Torques for Terminals*.

5.8.1.2 Mains Terminal Connections in 4-Drive Module Systems

Illustration 8.11 shows the bus bar connections for 4-drive systems. If a common terminal design is used, there is 1 set of mains terminals in each cabinet.

NOTICE

MULTIPLE MAINS CABLES

If connecting more than 1 set of mains terminals, use the same number, size, and length of cables for each set of terminals. For example, do not use 1 cable on one mains terminal and 2 cables on another mains terminal.

1. Measure between the common terminals and the 1st common point of a phase.
 - 1a For 6-pulse modules, it is typically the mains terminals.
 - 1b For 12-pulse drive modules, the set of cables from the 1st cabinet connects to the star-secondary winding of the 12-pulse transformer. The set from the 2nd cabinet connects to the delta-secondary winding of the 12-pulse transformer.
2. Strip a section of the outer cable insulation.
3. Connect the ground wire to the nearest ground terminal.
4. Connect the 3-phase mains wiring to terminals R/91, S/92, and T/93 using M10 screws.
5. Tighten the mains terminals. See *chapter 7.9.1 Tightening Torques for Terminals*.

5.8.2 12-Pulse Disconnecter Configuration

This section describes how to use a disconnecter for a 12-pulse drive system. When using disconnectors or contactors, make sure to install an interlock. When installed, both contactors or disconnectors should close to avoid 1 set of rectifiers not working. See *Illustration 8.1* for a diagram of these connections.

The selected contactors or mains disconnectors should have NC auxiliary contacts routed as shown. Connect the interlock in series with the Klixon switch of the brake. If only 1 contactor/disconnector has closed, the LCP shows the error *Brake IGBT Fault* and does not allow the drive system to power the motor. *Illustration 8.2* shows a BRF connection with 12-pulse disconnecter and interlock.

NOTICE

If the brake option is not selected, the Klixon switch can be bypassed.

NOTICE

Danfoss is not responsible for any failure or malfunction in the disconnecter/contactator switch.

5.8.3 Discharge Resistors

There are common positive and negative DC terminals on each drive module. If a shorter time to achieve the reduced run functionality is wanted, connect the external discharge resistor for quicker discharge of DC-link voltage. It is possible to connect a discharge resistor in an additional cabinet, through a contactor. This discharge contactor should have an interlock with the mains contactor/disconnector's auxiliary NC contacts to avoid a discharge when the drive system is powered.

Illustration 8.7 shows a 4-drive system with discharge resistor connections.

Base the selection of a discharge resistor on the energy and power levels given in *Table 5.12* for different power sizes, on both 12-pulse and 6-pulse systems.

5

FC 102 FC 202	N500	N560	N630	N710	N800	N1M0
FC 302	N450	N500	N560	N630	N710	N800
Drive modules required (HO rating)	2xN250	4xN160	4xN200	4xN200	4xN250	4xN250
Resistance required to reduce DC voltage below 50 V within 300 s (5 minutes), Ω	3036	2277	1822	1822	1518	1518
Power rating of resistor (W)	182	242	303	303	363	363
Energy dissipated by resistor (J)	7773	10365	12956	12956	15547	15547

Table 5.12 Discharge Resistors Recommended for Drive Systems with 380–480 V AC Mains Supply

FC 102 FC 202	N630	N710	N800	N900	N1M0	N1M2
FC 302	N560	N630	N710	N800	N900	N1M0
Drive modules required (HO rating)	2xN315	4xN200	4xN250	4xN250	4xN315	4xN315
Resistance required to reduce DC voltage below 50 V within 300 s (5 minutes), Ω	4571	3047	2285	2285	2285	2285
Power rating of resistor (W)	230	345	459	459	459	459
Energy dissipated by resistor (J)	8819	13229	17638	17638	17638	17638

Table 5.13 Discharge Resistors Recommended for Drive Systems with 525–690 V AC Mains Supply

NOTICE

Danfoss is not responsible for any failure or malfunction of the resistor, or for any misconnections made by the installer.

NOTICE

The wire used with the brake resistor should be double-insulated or have reinforced insulation.

5.9 Control Shelf Installation

The control shelf is preassembled. However, verify its various connections against the connection diagram. *Illustration 8.6* shows the various control shelf connections.

NOTICE

INCORRECT CONNECTION ORDER

If the connections are not made in the correct order, the drive modules do not function.

Check the following connections:

- Connection of the 44-pin ribbon cable between the MDCIC and the control card.
- When used, Safe Torque Off (STO) jumper connection must be made between the 12th and 27th pins to ensure proper STO operation.
- Connect the 44-pin ribbon cable to the MDCIC connectors in the correct order.
 - For systems with 4 drive modules, connect the ribbon cables to inverter 1, inverter 2, inverter 3, and then inverter 4.
 - For systems with 2 drive modules, connect the ribbon cables to inverter 1, then inverter 2. Leave inverter 3 and inverter 4 terminals unconnected.

5

NOTICE

SCALING CARD POSITION

If the scaling cards are not placed in the correct order, the drive modules do not function.

- Place the corresponding current scaling card on each respective connector.
 - For systems with 4 drive modules, Inverter 1, Inverter 2, Inverter 3, and Inverter 4.
 - For systems with 2 drive modules, Inverter 1 and Inverter 2. Leave connectors Inverter 3 and Inverter 4 unconnected.
- Do not reverse the current scaling card. Check that the PCB spacer is fixed on the MDCIC board.
- Ensure correct installation of the STO relay and the power supply on the DIN rail. Make the connections as shown in *Illustration 8.6*.
- The external supply (100–230 V) must be available at terminals 1 and 2 on the terminal block.
- Make more checks to ensure that the wiring of the fuse microswitches and the BRF jumpers are properly routed.
- Check that all the screws on the PCBs are secure.
- To ensure proper EMC protection, verify that the MDCIC plate is properly attached to the control shelf assembly.

5.10 Control Wiring Connections

Make sure to use the provided wire pathway when routing the control wires from the bottom of the drive system cabinet to the control terminal.

5.10.1 Control Cable Routing

Cable routing

Route the cable inside the drive cabinets as shown in *Illustration 5.8*. Wire routing for a 2-drive configuration is identical, except for the number of drive modules used.

5

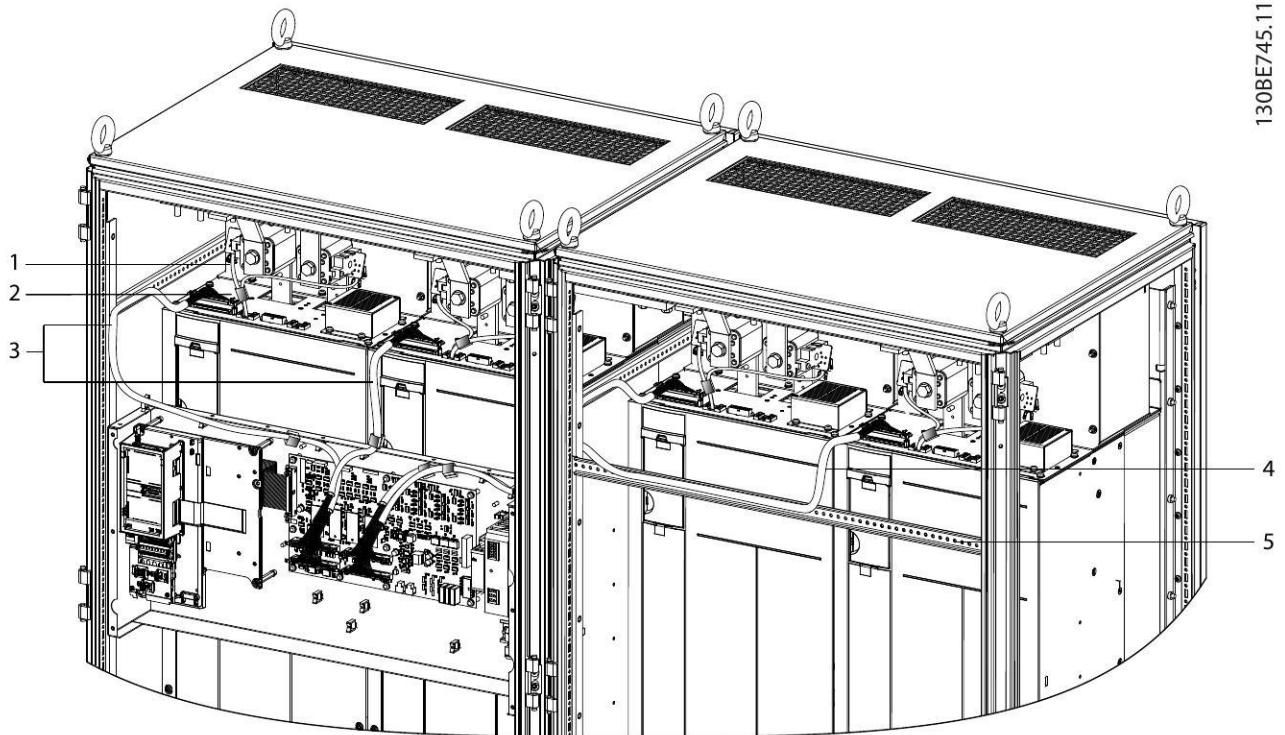

1	Microswitch cable	4	44-pin ribbon cable from MDCIC to drive module 4
2	Ferrite core	5	Bracket to support ribbon cable
3	44-pin ribbon cable from MDCIC to drive modules 1 and 2	-	-

Illustration 5.8 Control Cable Routing for a 4-Drive System

5.10.2 Control Wiring

- Isolate the control wiring from the high-power components in the drive modules.
- When the drive module is connected to a thermistor, ensure that the thermistor control wiring is shielded and reinforced/double insulated. A 24 V DC supply voltage is recommended. See *Illustration 5.9*.

NOTICE

MINIMIZE INTERFERENCE

To minimize interference, keep control wires as short as possible and separate them from high-power cables.

The control terminals are on the control shelf, directly below the LCP. The control cable is routed at the bottom of the cabinet.

1. Follow the designated control cable routing as shown in *chapter 5.10.1 Control Cable Routing*.
2. Tie down all control wires.
3. Ensure optimum electrical immunity by properly connecting the shields.

Fieldbus connection

For details, see the relevant fieldbus instructions.

1. Follow the designated control cable routing as shown in *chapter 5.10.1 Control Cable Routing*.
2. Tie down all control wires.
3. Connect the relevant options on the control card.

5.10.2.1 Control Terminal Types

Illustration 5.9 shows the removable frequency converter connectors. Terminal functions and default settings are summarized in *Table 5.14*. See *Illustration 5.9* for the location of the control terminals within the unit.

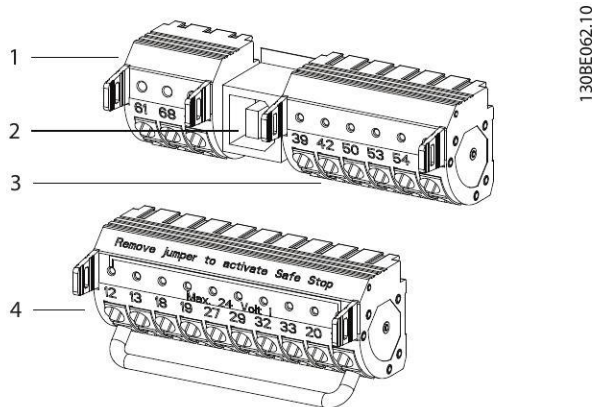

1	Terminals (+)68 and (-)69 are for an RS485 serial communication connection.
2	USB port available for use with the MCT 10 Set-up Software.
3	2 analog inputs, 1 analog output, 10 V DC supply voltage, and commons for the inputs and output.
4	4 programmable digital inputs terminals, 2 extra digital terminals programmable as either input or output, a 24 V DC terminal supply voltage, and a common for optional customer-supplied 24 V DC voltage.

Illustration 5.9 Control Terminal Locations

Terminal	Parameter	Default setting	Description
Digital inputs/outputs			
12, 13	–	+24 V DC	Digital inputs. 24 V DC supply voltage. Maximum output current is 200 mA total for all 24 V loads. Usable for digital inputs and external transducers.
18	<i>Parameter 5-10 Terminal 18 Digital Input</i>	[8] Start	
19	<i>Parameter 5-11 Terminal 19 Digital Input</i>	[10] Reversing	
32	<i>Parameter 5-14 Terminal 32 Digital Input</i>	[0] No operation	
33	<i>Parameter 5-15 Terminal 33 Digital Input</i>	[0] No operation	
27	<i>Parameter 5-12 Terminal 27 Digital Input</i>	[2] Coast inverse	
29	<i>Parameter 5-13 Terminal 29 Digital Input</i>	[14] Jog	
20	–	–	Common for digital inputs and 0 V potential for 24 V supply.
37	–	Safe Torque Off (STO)	Safe input (optional). Used for STO.
Analog inputs/outputs			
39	–	–	Common for analog output Programmable analog output. The analog signal is 0–20 mA or 4–20 mA at a maximum of 500 Ω 10 V DC analog supply voltage. 15 mA maximum commonly used for potentiometer or thermistor.
42	<i>Parameter 6-50 Terminal 42 Output</i>	Speed 0 – high limit	
50	–	+10 V DC	
53	<i>Parameter group 6-1* Analog Input 1</i>	Reference	Analog input. Selectable for voltage or current. Switches A53 and A54 select mA or V.
54	<i>Parameter group 6-2* Analog Input 2</i>	Feedback	
55	–	–	Common for analog input
Serial communication			
61	–	–	Integrated RC-filter for cable shield. ONLY for connecting the shield when experiencing EMC problems.
68 (+)	<i>Parameter group 8-3 FC Port Settings</i>	–	RS485 Interface. A control card switch is provided for termination resistance.
69 (-)	<i>Parameter group 8-3 FC Port Settings</i>	–	
Relays			
01, 02, 03	<i>Parameter 5-40 Function Relay [0]</i>	[9] Alarm	Form C relay output. Usable for AC or DC voltage and resistive or inductive loads.
04, 05, 06	<i>Parameter 5-40 Function Relay [1]</i>	[5] Running	

Table 5.14 Terminal Description

Extra terminals:

- Two form C relay outputs. Location of the outputs depends on frequency converter configuration.
- Terminals on built-in optional equipment. See the manual provided with the equipment option.

5.10.2.2 Wiring to Control Terminals

Terminal plugs can be removed for easy access.

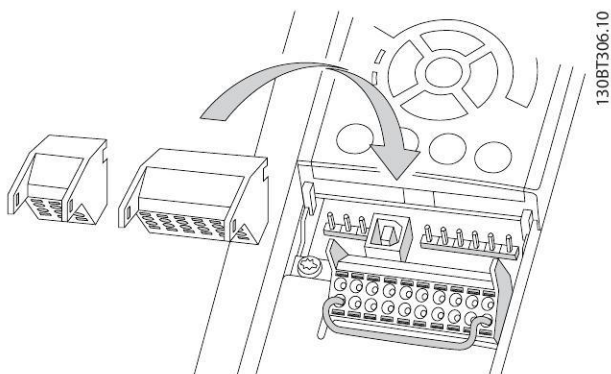

Illustration 5.10 Removal of Control Terminals

5.10.2.3 Enabling Motor Operation (Terminal 27)

A jumper wire is required between terminal 12 (or 13) and terminal 27 for the frequency converter to operate when using factory default programming values.

- Digital input terminal 27 is designed to receive 24 V DC external interlock command.
- When no interlock device is used, wire a jumper between control terminal 12 (recommended) or 13 to terminal 27. The jumper provides an internal 24 V signal on terminal 27.
- When the status line at the bottom of the LCP reads *AUTO REMOTE COAST*, it indicates that the unit is ready to operate but is missing an input signal on terminal 27.
- When factory installed optional equipment is wired to terminal 27, do not remove that wiring.

5.10.2.4 Voltage/Current Input Selection (Switches)

The analog mains terminals 53 and 54 allow the setting of the input signal to voltage (0–10 V) or current (0/4–20 mA). See *Illustration 5.9* for the location of the control terminals within the drive system.

Default parameter settings:

- Terminal 53: Speed reference signal in open loop (see *parameter 16-61 Terminal 53 Switch Setting*).
- Terminal 54: Feedback signal in closed loop (see *parameter 16-63 Terminal 54 Switch Setting*).

NOTICE

REMOVE POWER

Remove power to the frequency converter before changing switch positions.

1. Remove the LCP (see *Illustration 5.11*).
2. Remove any optional equipment covering the switches.
3. Set switches A53 and A54 to select the signal type. U selects voltage, I selects current.

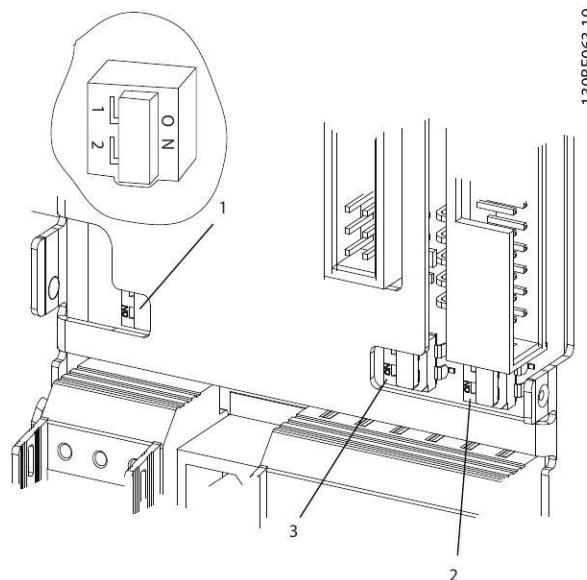

1	Bus termination switch
2	A54 switch
3	A53 switch

Illustration 5.11 Locations of Bus Termination Switch and Switches A53 and A54

5.10.2.5 RS485 Serial Communication

An RS485 serial communications bus can be used with the drive system. Up to 32 nodes can be connected as a bus, or via drop cables from a common trunk line to 1 network segment. Repeaters can be used to divide network segments. Each repeater functions as a node within the segment in which it is installed. Each node connected within a given network must have a unique node address, across all segments.

- Connect RS485 serial communication wiring to terminals (+)68 and (-)69.
- Terminate each segment at both ends, using either the termination switch (bus term on/off, see *Illustration 5.11*) on the drive module, or a biased network termination resistor.
- Connect a large surface of the shield to ground, for example with a cable clamp or a conductive cable gland.
- Maintain the same ground potential throughout the network by applying potential-equalizing cables.
- Prevent impedance mismatch by using the same type of cable throughout the entire network.

Cable	Shielded twisted pair (STP)
Impedance	120 Ω
Maximum cable length	
Station-to-station [m (ft)]	500 (1640)
Total including drop lines [m (ft)]	1200 (3937)

Table 5.15 Cable Information

5.10.3 Safe Torque Off (STO)

To run STO, extra wiring for the drive system is required. Refer to *VLT® Frequency Converters Safe Torque Off Operating Instructions* for further information.

5.11 Relay Output

The relay terminal is on the top plate of the drive module. See *Illustration 3.1*. Use an extended wiring harness to connect the relay terminal of drive module 1 (the drive module on the far left) to the terminal blocks on the control shelf.

NOTICE

For reference, drive modules are numbered from left to right.

Relay 1

- Terminal 01: Common
- Terminal 02: Normally open 400 V AC
- Terminal 03: Normally closed 240 V AC

Relay 2

- Terminal 04: Common
- Terminal 05: Normally open 400 V AC
- Terminal 06: Normally closed 240 V AC

Relay 1 and relay 2 are programmed in *parameter 5-40 Function Relay*, *parameter 5-41 On Delay, Relay*, and *parameter 5-42 Off Delay, Relay*.

Use VLT® Relay Card MCB 105 option module for extra relay outputs.

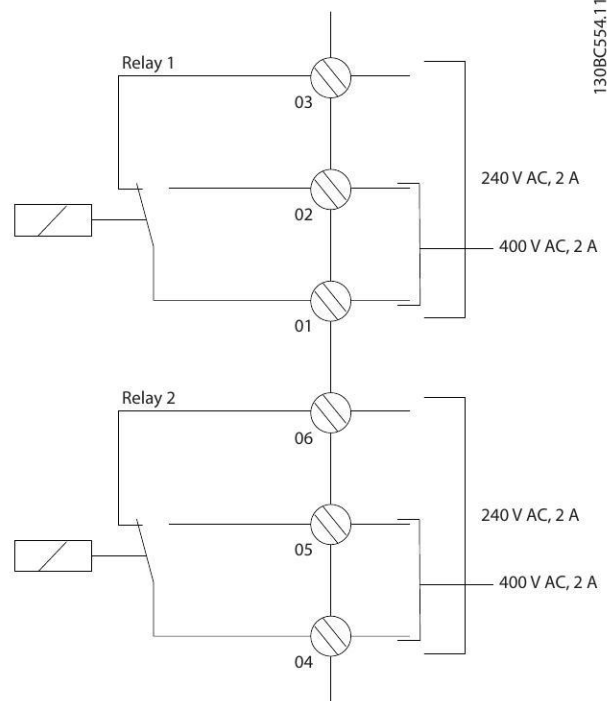

130BC554.11

Illustration 5.12 Extra Relay Outputs

5.12 EMC Recommendations

The following is a guideline to good engineering practice when installing frequency converters. Follow these guidelines in compliance with EN/IEC 61800-3 *First environment*. If the installation is in EN/IEC 61800-3 *Second environment*, industrial networks, or in an installation with its own transformer, deviation from these guidelines is allowed but not recommended.

Good engineering practice to ensure EMC-correct electrical installation:

- Use only braided shielded/armored motor cables and braided shielded control cables. The shield provides a minimum coverage of 80%. The shield material must be metal, not limited to but typically copper, aluminum, steel, or lead. There are no special requirements for the mains cable.
- Installations using rigid metal conduits are not required to use shielded cable, but the motor cable must be installed in conduit separate from the control and mains cables. Full connection of the conduit from the frequency converter to the motor is required. The EMC performance of flexible conduits varies a lot and information from the manufacturer must be obtained.
- Connect the shield conduit to ground at both ends for motor cables and for control cables. Sometimes, it is not possible to connect the

shield in both ends. If so, connect the shield at the frequency converter. See also *chapter 5.12.2 Grounding of Shielded Control Cables*.

- Avoid terminating the shield with twisted ends (pigtailed). It increases the high frequency impedance of the shield, which reduces its effectiveness at high frequencies. Use low impedance cable clamps or EMC cable glands instead.
- Avoid using unshielded motor or control cables inside cabinets housing the frequency converter, whenever possible.

Leave the shield as close to the connectors as possible.

Illustration 5.13 shows an example of an EMC-correct electrical installation of an IP20 frequency converter. The frequency converter is fitted in an installation cabinet with an output contactor and connected to a PLC, which is installed in a separate cabinet. Other ways of doing the installation could have just as good an EMC performance, provided the guidelines to engineering practice are followed.

If the installation is not carried out according to the guideline, and if unshielded cables and control wires are used, some emission requirements are not in compliance, although the immunity requirements are fulfilled.

5

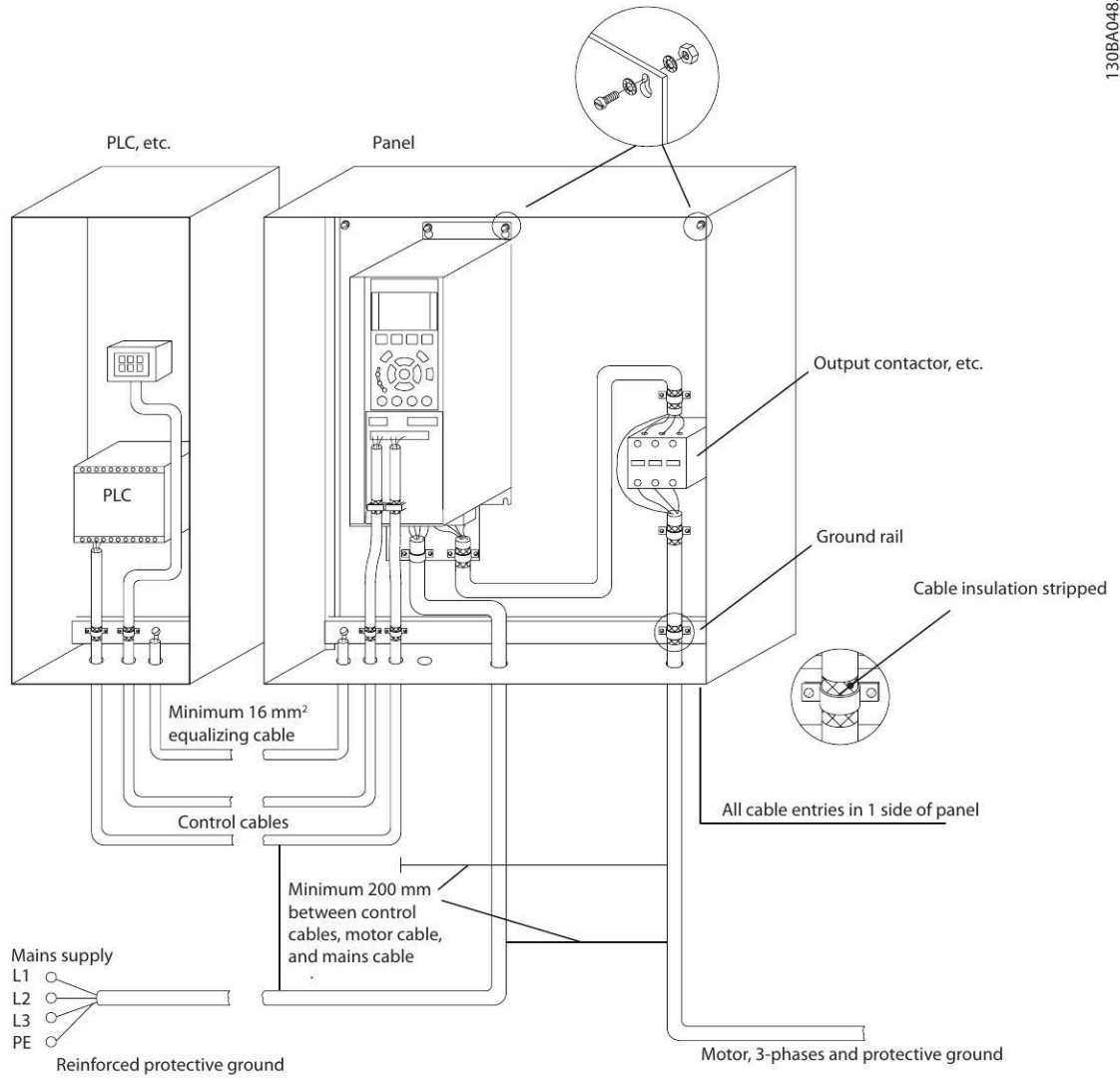

Illustration 5.13 EMC-correct Electrical Installation of a Frequency Converter in Cabinet

5.12.1 Using Shielded Control Cables

Danfoss recommends braided shielded/armored cables to optimize EMC immunity of the control cables and the EMC emission from the motor cables.

The ability of a cable to reduce the incoming and outgoing radiation of electric noise depends on the transfer impedance (Z_T). The shield of a cable is normally designed to reduce the transfer of electric noise. However, a shield with a lower transfer impedance (Z_T) value is more effective than a shield with a higher transfer impedance (Z_T).

Cable manufacturers rarely state the transfer impedance (Z_T), but it is often possible to estimate transfer impedance (Z_T) by assessing the physical design of the cable, such as:

- The conductivity of the shield material.
- The contact resistance between the individual shield conductors.
- The shield coverage, that is the physical area of the cable covered by the shield - often stated as a percentage value.
- Shield type, that is braided or twisted pattern.

5

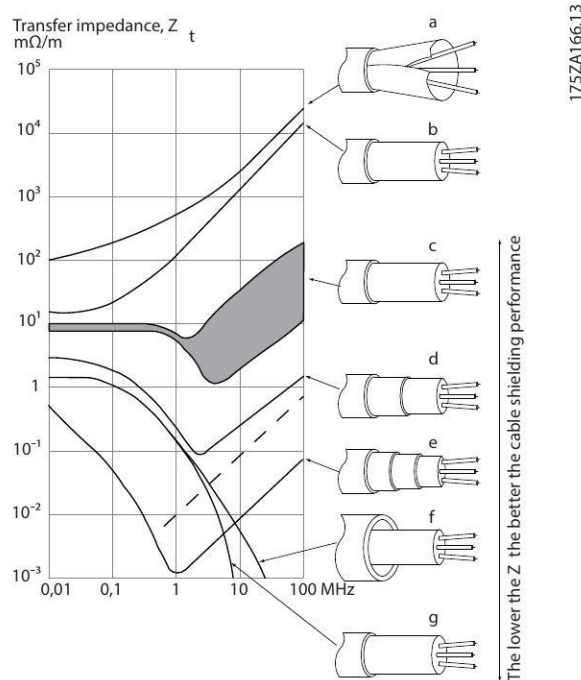

a	Aluminum-clad with copper wire.
b	Twisted copper wire or armored steel wire cable.
c	Single-layer braided copper wire with varying percentage shield coverage (this type of cable is the typical Danfoss reference cable).
d	Double-layer braided copper wire.
e	Twin layer of braided copper wire with a magnetic, shielded/armored intermediate layer.
f	Cable that runs in copper tube or steel tube.
g	Lead cable with 1.1 mm (0.04 in) wall thickness.

Illustration 5.14 Cable Shielding Performance

5.12.2 Grounding of Shielded Control Cables

Correct shielding

The preferred method usually is to secure control and serial communication cables with shielding clamps provided at both ends to ensure best possible high frequency cable contact. If the ground potential between the frequency converter and the PLC is different, electric noise can occur that disturbs the entire system. Solve this problem by fitting an equalizing cable next to the control cable. Minimum cable cross-section: 16 mm² (4 AWG).

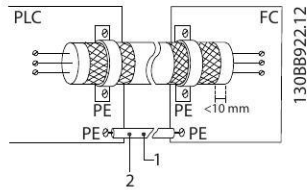

1	Minimum 16 mm ² (4 AWG)	2	Equalizing cable
---	------------------------------------	---	------------------

Illustration 5.15 Correct Shielding

50/60 Hz ground loops

With long control cables, ground loops can occur. To eliminate ground loops, connect 1 end of the shield-to-ground with a 100 nF capacitor (keeping leads short).

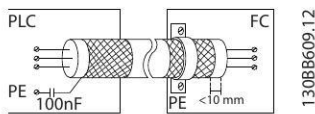
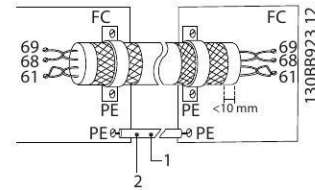

Illustration 5.16 Avoiding Ground Loops

Avoid EMC noise on serial communication

This terminal is connected to ground via an internal RC link. To reduce interference between conductors, use twisted-pair cables.



1	Minimum 16 mm ² (4 AWG)	2	Equalizing cable
---	------------------------------------	---	------------------

Illustration 5.17 Recommended Method for Avoiding EMC Noise

Alternatively, the connection to terminal 61 can be omitted:

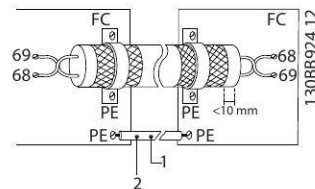

1	Minimum 16 mm ² (4 AWG)	2	Equalizing cable
---	------------------------------------	---	------------------

Illustration 5.18 Shielding without Using Terminal 61

6 Initial Start-up

6.1 Pre-start Check List

Before completing installation of the unit, inspect the entire installation as detailed in *Table 6.1*. Mark the check-list items when they are completed.

Inspect for	Description	<input checked="" type="checkbox"/>
Auxiliary equipment	<ul style="list-style-type: none"> Look for auxiliary equipment, switches, disconnects, or input fuses/circuit breakers that reside on the input power side of the drive system or on the output side to the motor. Ensure that they are ready for full-speed operation. Check function and installation of any sensors used for feedback to the drive system. Remove any power factor correction caps on motor(s). Adjust any power factor correction caps on the mains side and ensure that they are dampened. 	
Cable routing	<ul style="list-style-type: none"> Ensure that motor wiring and control wiring are separated or shielded, or in 3 separate metallic conduits for high-frequency interference isolation. 	
Control wiring	<ul style="list-style-type: none"> Check for broken or damaged wires and loose connections. Check that control wiring is isolated from power and motor wiring for noise immunity. Check the voltage source of the signals, if necessary. Using shielded cable or twisted pair is recommended. Ensure that the shield is terminated correctly. Check that the DC-link fuse and microswitch fixtures are correct. Check the microswitch cabling and the connectors in the top of the drive module. 	
Cooling clearance	<ul style="list-style-type: none"> Check that there is 225 mm (9 in) of top clearance for adequate cooling. 	
Ambient conditions	<ul style="list-style-type: none"> Check that requirements for ambient conditions are met. 	
Fusing and circuit breakers	<ul style="list-style-type: none"> Check for proper fusing or circuit breakers. Check that all fuses are inserted firmly and are in operational condition, and that all circuit breakers are in the open position. 	
Grounding	<ul style="list-style-type: none"> Check for good ground connections that are tight and free of oxidation. Grounding to conduit, or mounting the back panel to a metal surface, is not a suitable grounding. 	
Input and output power wiring	<ul style="list-style-type: none"> Check for loose connections. Check that motor and mains are in separate conduit or separated shielded cables. Check that the shields are properly grounded. Check that the DC-link connections are properly made. 	
Panel interior	<ul style="list-style-type: none"> Inspect that the unit interior is free of dirt, metal chips, moisture, and corrosion. Check that the unit is mounted on an unpainted, metal surface. 	
Switches	<ul style="list-style-type: none"> Ensure that all switch and disconnect settings are in the proper positions. 	
Vibration	<ul style="list-style-type: none"> Check that the unit is mounted solidly, or that shock mounts are used, as necessary. Check for an unusual amount of vibration. 	

Table 6.1 Installation Check List

6

CAUTION**POTENTIAL HAZARD IN THE EVENT OF INTERNAL FAILURE**

There is a risk of personal injury when the drive modules are not properly closed.

- Before applying power, ensure that all safety covers are in place and securely fastened.

6.2 Safety Instructions

See *chapter 2 Safety* for general safety instructions.

WARNING**HIGH VOLTAGE**

The drive system contains high voltage when connected to AC mains input power, DC supply, or load sharing. Failure to perform installation, startup, and maintenance by qualified personnel can result in death or serious injury.

Before applying power:

1. Ensure that input power to the unit is OFF and locked out. Do not rely on the drive system's disconnect switches for input power isolation.
2. Verify that there is no voltage on mains terminals L1 (91), L2 (92), and L3 (93), phase-to-phase, and phase-to-ground.
3. Verify that there is no voltage on motor terminals 96 (U), 97 (V), and 98 (W), phase-to-phase, and phase-to-ground.
4. Confirm continuity of the motor by measuring resistance values on U–V (96–97), V–W (97–98), and W–U (98–96).
5. Check for proper grounding of the drive system and the motor.
6. Inspect the drive system for loose connections on the terminals.
7. Confirm that the supply voltage matches the voltage of the drive system and the motor.

6.3 Applying Power

WARNING**UNINTENDED START**

When the drive system is connected to AC mains, the motor can start at any time. Unintended start during programming, service, or repair work can result in death, serious injury, or property damage. The motor can start via any of the following:

- An external switch.
- A fieldbus command.
- An input reference signal from the LCP.
- A cleared fault condition.
- Remote operation using MCT 10 Set-up Software.

To prevent unintended motor start:

- Disconnect the drive system from AC mains.
- Press [Off/Reset] on the LCP, before programming parameters.
- The drive system, motor, and any driven equipment must be fully wired and assembled when the drive is connected to AC mains.

Apply power to the drive system, according to the following steps:

1. Confirm that the input voltage is balanced within 3%. If not, correct the input voltage imbalance before proceeding. Repeat this procedure after the voltage correction.
2. Ensure that the wiring of any optional equipment matches the installation application.
3. Ensure that all operator devices are in the OFF position.
4. Close all panel doors and securely fasten all covers.
5. Apply power to the drive system. DO NOT start the drive system now. For units with a disconnect switch, turn the switch to the ON position to apply power to the drive system.

6.4 Configuring the Drive System

Before the drive system is fully functional, it is necessary to configure the unit on the local control panel (LCP). The top-level drive system label is needed for the following steps. Refer to *Illustration 4.1*.

1. Apply power. At power-up, the LCP display shows *alarm 250, New spare part*.
2. Press [Main Menu] twice on the LCP. See *Illustration 6.1*.
3. Press the navigation keys and the [OK] key to navigate to *parameter group 14-** Special Functions*. Then scroll down to *parameter 14-23 Typecode Setting*.
4. Scroll through the submenu to match the 39 characters in the typecode to the 20 index groups. See *Table 6.2*. Press [OK] to enter the value.
5. At index number 20, select Save to EEPROM and press [OK]. When the system finishes writing the EEPROM data, the display shows *No Function*.
6. Remove power to the drive system, and then reapply power. Press [RESET] to clear the alarm.

NOTICE

INCORRECT TYPECODE ENTERED

If the wrong typecode is entered, scroll to *parameter 14-29 Service Code* and enter 00006100. This step allows access to *parameter 14-23 Typecode Setting* to reenter the typecode.

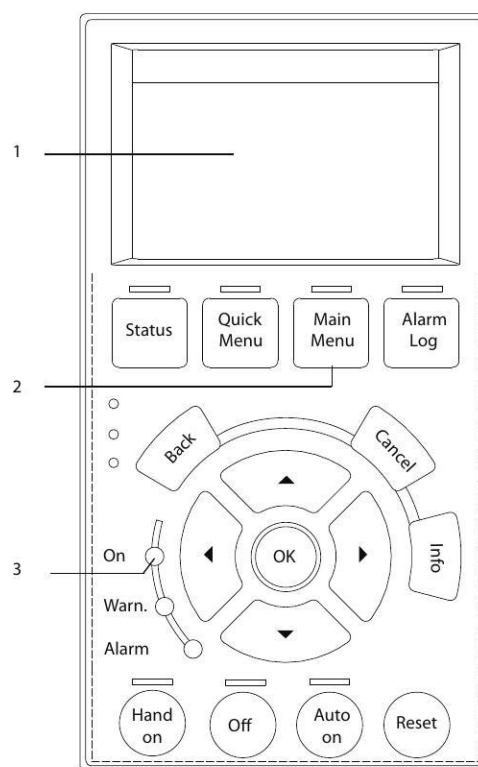

130BE712.10

1	LCP display
2	[Main Menu] key
3	Power-on indicator light

Illustration 6.1 Local Control Panel (LCP)

Index	Description	Typecode units
[0]	Product group	1-3
[1]	Series	4-6
[2]	Power	7-10
[3]	Voltage	11-12
[4]	Enclosure	13-15
[5]	RFI filter	16-17
[6]	Brake & stop	18
[7]	Display	19
[8]	Coating	20
[9]	Mains options	21
[10]	Adaptation A	22
[11]	Adaptation B	23
[12]	Software	24-27
[13]	Language	28
[14]	Options A	29-30
[15]	Options B	31-32
[16]	Options C0	33-34
[17]	Options C1	35
[18]	Options C	36-37
[19]	Options D	38-39

Table 6.2 Typecode Index

6.5 Testing the Motor Operation

1. Press [Main Menu] twice on the LCP.
2. Press the navigation keys and the [OK] key to navigate to *parameter group 1-** Load and Motor* and press [OK].
3. Navigate to *parameter 1-23 Motor Frequency* and enter the frequency from the motor nameplate.
4. Navigate to *parameter 1-23 Motor Frequency* and enter the current from the motor nameplate.
5. Navigate to *parameter 1-25 Motor Nominal Speed* and enter the speed from the motor nameplate.
6. Press [Status] to return to the operational display.
7. Press [Hand On].
8. Press [▲] to accelerate the motor.
9. Press [▼] to decelerate the motor.
10. Press [Off].

6

7 Specifications

7.1 Power-dependent Specifications

7.1.1 VLT[®] HVAC Drive FC 102

Power range	N315	N355	N400	N450	N500
Drive modules	2	2	2	2	2
Rectifier configuration	12-pulse				6-pulse/12-pulse
High/normal load	NO	NO	NO	NO	NO
Output current [A]					
Continuous (at 380–440 V)	588	658	745	800	880
Intermittent (60 s overload) at 400 V	647	724	820	880	968
Continuous (at 460/500 V)	535	590	678	730	780
Intermittent (60 s overload) at 460/500 V	588	649	746	803	858
Input current [A]					
Continuous (at 400 V)	567	647	733	787	875
Continuous (at 460/500 V)	516	580	667	718	759
Power losses [W]					
Drive modules at 400 V	5825	6110	7069	7538	8468
Drive modules at 460 V	4998	5964	6175	6609	7140
AC bus bars at 400 V	550	555	561	565	575
AC bus bars at 460 V	548	551	556	560	563
DC bus bars during regeneration	93	95	98	101	105
Maximum cable size [mm² (mcm)]					
Mains	4x120 (250)				4x150 (300)
Motor	4x120 (250)				4x150 (300)
Brake	4x70 (2/0)			4x95 (3/0)	
Regeneration terminals ¹⁾	4x120 (250)		4x150 (300)	6x120 (250)	
Maximum external mains fuses					
6-pulse configuration	–	–	–	–	600 V, 1600 A
12-pulse configuration	700 A, 600 V				–

Table 7.1 FC 102, 380–480 V AC Mains Supply (2-Drive System)

1) If Danfoss bus bar kit is used.

7

Power range	N560	N630	N710	N800	N1M0
Drive modules	4	4	4	4	4
Rectifier configuration	6-pulse/12-pulse				
High/normal load	NO	NO	NO	NO	NO
Output current [A]					
Continuous (at 380–440 V)	990	1120	1260	1460	1720
Intermittent (60 s overload) at 400 V	1089	1232	1386	1606	1892
Continuous (at 460/500 V)	890	1050	1160	1380	1530
Intermittent (60 s overload) at 460/500 V	979	1155	1276	1518	1683
Input current [A]					
Continuous (at 400 V)	964	1090	1227	1422	1675
Continuous (at 460/500 V)	867	1022	1129	1344	1490
Power losses [W]					
Drive modules at 400 V	8810	10199	11632	13253	16463
Drive modules at 460 V	7628	9324	10375	12391	13958
AC bus bars at 400 V	665	680	695	722	762
AC bus bars at 460 V	656	671	683	710	732
DC bus bars during regeneration	218	232	250	276	318
Maximum cable size [mm² (mcm)]					
Mains	4x185 (350)	8x120 (250)			
Motor	4x185 (350)	8x120 (250)			
Brake	8x70 (2/0)			8x95 (3/0)	
Regeneration terminals ¹⁾	6x120 (250)	8x120 (250)		8x150 (300)	10x150 (300)
Maximum external mains fuses					
6-pulse configuration	600 V, 1600 A	600 V, 2000 A		600 V, 2500 A	
12-pulse configuration	600 V, 700 A	600 V, 900 A			600 V, 1500 A

Table 7.2 FC 102, 380–480 V AC Mains Supply (4-Drive System)

1) If Danfoss bus bar kit is used.

Power range	N315	N400	N450	N500	N560	N630
Drive modules	2	2	2	2	2	2
Rectifier configuration	12-pulse					
High/normal load	NO	NO	NO	NO	NO	NO
Output current [A]						
Continuous (at 550 V)	360	418	470	523	596	630
Intermittent (60 s overload) at 550 V	396	360	517	575	656	693
Continuous (at 575/690 V)	344	400	450	500	570	630
Intermittent (60 s overload) at 575/690 V	378	440	495	550	627	693
Input current [A]						
Continuous (at 550 V)	355	408	453	504	574	607
Continuous (at 575 V)	339	490	434	482	549	607
Continuous (at 690 V)	352	400	434	482	549	607
Power losses [W]						
Drive modules at 575 V	4401	4789	5457	6076	6995	7431
Drive modules at 690 V	4352	4709	5354	5951	6831	7638
AC bus bars at 575 V	540	541	544	546	550	553
DC bus bars during regeneration	88	88.5	90	91	186	191
Maximum cable size [mm² (mcm)]						
Mains	2x120 (250)	4x120 (250)				
Motor	2x120 (250)	4x120 (250)				
Brake	4x70 (2/0)				4x95 (3/0)	
Regeneration terminals ¹⁾	4x120 (250)					
Maximum external mains fuses	700 V, 550 A			700 V, 630 A		

7
Table 7.3 FC 102, 525–690 V AC Mains Supply (2-Drive System)
1) If Danfoss bus bar kit is used.

Power range	N710	N800	N900	N1M0	N1M2
Drive modules	4	4		4	4
Rectifier configuration	6-pulse/12-pulse				
High/normal load	NO	NO	NO	NO	NO
Output current [A]					
Continuous (at 550 V)	763	889	988	1108	1317
Intermittent (60 s overload) at 550 V	839	978	1087	1219	1449
Continuous (at 575/690 V)	730	850	945	1060	1260
Intermittent (60 s overload) at 575/690 V	803	935	1040	1166	1590
Input current [A]					
Continuous (at 550 V)	743	866	962	1079	1282
Continuous (at 575 V)	711	828	920	1032	1227
Continuous (at 690 V)	711	828	920	1032	1227
Power losses [W]					
Drive modules at 575 V	8683	10166	11406	12852	15762
Drive modules at 690 V	8559	9996	11188	12580	15358
AC bus bars at 575 V	644	653	661	672	695
DC bus bars during regeneration	198	208	218	231	256
Maximum cable size [mm² (mcm)]					
Mains	4x120 (250)	6x120 (250)		8x120 (250)	
Motor	4x120 (250)	6x120 (250)		8x120 (250)	
Brake	8x70 (2/0)			8x95 (3/0)	
Regeneration terminals ¹⁾	4x150 (300)	6x120 (250)		6x150 (300)	8x120 (250)
Maximum external mains fuses					
6-pulse configuration	700 V, 1600 A			700 V, 2000 A	
12-pulse configuration	700 V, 900 A			700 V, 1500 A	

Table 7.4 FC 102, 525–690 V AC Mains Supply (4-Drive System)

1) If Danfoss bus bar kit is used.

7.1.2 VLT[®] AQUA Drive FC 202

Power range	N315		N355		N400		N450		N500	
Drive modules	2		2		2		2		2	
Rectifier configuration	12-pulse								6-pulse/12-pulse	
High/normal load	HO	NO	HO	NO	HO	NO	HO	NO	HO	NO
Output current [A]										
Continuous (at 400 V)	480	588	600	658	658	745	695	800	810	880
Intermittent (60 s overload) at 400 V	720	647	900	724	987	820	1043	880	1215	968
Continuous (at 460/500 V)	443	535	540	590	590	678	678	730	730	780
Intermittent (60 s overload) at 460/500 V	665	588	810	649	885	746	1017	803	1095	858
Input current [A]										
Continuous (at 400 V)	463	567	590	647	647	733	684	787	779	857
Continuous (at 460/500 V)	427	516	531	580	580	667	667	718	711	759
Power losses [W]										
Drive modules at 400 V	4505	5825	5502	6110	6110	7069	6375	7538	7526	8468
Drive modules at 460 V	4063	4998	5384	5964	5271	6175	6070	6609	6604	7140
AC bus bars at 400 V	545	550	551	555	555	561	557	565	566	575
AC bus bars at 460 V	543	548	548	551	551	556	556	560	560	563
DC bus bars during regeneration	93	93	95	95	98	98	101	101	105	105
Maximum cable size [mm ² (mcm)]										
Mains	4x120 (250)								4x150 (300)	
Motor	4x120 (250)								4x150 (300)	
Brake	4x70 (2/0)						4x95 (3/0)			
Regeneration terminals ¹⁾	4x120 (250)				6x120 (250)		6x120 (250)			
Maximum external mains fuses										
6-pulse configuration	-		-		-		-		600 V, 1600 A	
12-pulse configuration	600 V, 700 A								600 V, 900 A	

7

Table 7.5 FC 202, 380–480 V AC Mains Supply (2-Drive System)

1) If Danfoss bus bar kit is used.

Power range	N560		N630		N710		N800		N1M0	
Drive modules	4		4		4		4		4	
Rectifier configuration	6-pulse/12-pulse									
High/normal load	HO	NO	HO	NO	HO	NO	HO	NO	HO	NO
Output current [A]										
Continuous (at 400 V)	880	990	990	1120	1120	1260	1260	1460	1460	1720
Intermittent (60 s overload) at 400 V	1320	1089	1485	1232	1680	1386	1890	1606	2190	1892
Continuous (at 460/500 V)	780	890	890	1050	1050	1160	1160	1380	1380	1530
Intermittent (60 s overload) at 460/500 V	1170	979	1335	1155	1575	1276	1740	1518	2070	1683
Input current [A]										
Continuous (at 400 V)	857	964	964	1090	1090	1227	1127	1422	1422	1675
Continuous (at 460 V)	759	867	867	1022	1022	1129	1129	1344	1344	1490
Power losses [W]										
Drive modules at 400 V	7713	8810	8918	10199	10181	11632	11390	13253	13479	16463
Drive modules at 460 V	6641	7628	7855	9324	9316	10375	12391	12391	12376	13958
AC bus bars at 400 V	655	665	665	680	680	695	695	722	722	762
AC bus bars at 460 V	647	656	656	671	671	683	683	710	710	732
DC bus bars during regeneration	218	218	232	232	250	250	276	276	318	318
Maximum cable size [mm ² (mcm)]										
Mains	4x185 (350)			8x125 (250)						
Motor	4x185 (350)			8x125 (250)						
Brake	8x70 (2/0)						8x95 (3/0)			
Regeneration terminals ¹⁾	6x125 (250)		8x125 (250)				8x150 (300)		10x150 (300)	
Maximum external mains fuses										
6-pulse configuration	600 V, 1600 A		600 V, 2000 A				600 V, 2500 A			
12-pulse configuration	600 V, 900 A				600 V, 1500 A					

Table 7.6 FC 202, 380–480 V AC Mains Supply (4-Drive System)

1) If Danfoss bus bar kit is used.

Power range	N315		N400		N450	
Drive modules	2		2		2	
Rectifier configuration	12-pulse					
High/normal load	HO	NO	HO	NO	HO	NO
Output current [A]						
Continuous (at 550 V)	303	360	360	418	395	470
Intermittent (60 s overload) at 550 V	455	396	560	460	593	517
Continuous (at 575/690 V)	290	344	344	400	380	450
Intermittent (60 s overload) at 575/690 V	435	378	516	440	570	495
Input current [A]						
Continuous (at 550 V)	299	355	355	408	381	453
Continuous (at 575 V)	286	339	339	490	366	434
Continuous (at 690 V)	296	352	352	400	366	434
Power losses [W]						
Drive modules at 575 V	3688	4401	4081	4789	4502	5457
Drive modules at 690 V	3669	4352	4020	4709	4447	5354
AC bus bars at 575 V	538	540	540	541	540	544
DC bus bars during regeneration	88	88	89	89	90	90
Maximum cable size [mm ² (mcm)]						
Mains	2x120 (250)		4x120 (250)			
Motor	2x120 (250)		4x120 (250)			
Brake	4x70 (2/0)					
Regeneration terminals ¹⁾	4x120 (250)					
Maximum external mains fuses	700 V, 550 A					

7

Table 7.7 FC 202, 525–690 V AC Mains Supply (2-Drive System)

1) If Danfoss bus bar kit is used.

Power range	N500		N560		N630	
Drive modules	2		2		2	
Rectifier configuration	12-pulse					
High/normal load	HO	NO	HO	NO	HO	NO
Output current [A]						
Continuous (at 550 V)	429	523	523	596	596	630
Intermittent (60 s overload) at 550 V	644	575	785	656	894	693
Continuous (at 575/690 V)	410	500	500	570	570	630
Intermittent (60 s overload) at 575/690 V	615	550	750	627	627	693
Input current [A]						
Continuous (at 550 V)	413	504	504	574	574	607
Continuous (at 575 V)	395	482	482	549	549	607
Continuous (at 690 V)	395	482	482	549	549	607
Power losses [W]						
Drive modules at 575 V	4892	6076	6016	6995	6941	7431
Drive modules at 690 V	4797	5951	5886	6831	6766	7638
AC bus bars at 575 V	542	546	546	550	550	553
DC bus bars during regeneration	91	91	186	186	191	191
Maximum cable size [mm ² (mcm)]						
Mains	4x120 (250)					
Motor	4x120 (250)					
Brake	4x70 (2/0)		4x95 (3/0)			
Regeneration terminals ¹⁾	4x120 (250)					
Maximum external mains fuses	700 V, 630 A					

Table 7.8 FC 202, 525–690 V AC Mains Supply (2-Drive System)

1) If Danfoss bus bar kit is used.

Power range	N710		N800		N900		N1M0		N1M2	
Drive modules	4		4		4		4		4	
Rectifier configuration	6-pulse/12-pulse									
High/normal load	HO	NO	HO	NO	HO	NO	HO	NO	HO	NO
Output current [A]										
Continuous (at 550 V)	659	763	763	889	889	988	988	1108	1108	1317
Intermittent (60 s overload) at 550 V	989	839	1145	978	1334	1087	1482	1219	1662	1449
Continuous (at 575/690 V)	630	730	730	850	850	945	945	1060	1060	1260
Intermittent (60 s overload) at 575/690 V	945	803	1095	935	1275	1040	1418	1166	1590	1590
Input current [A]										
Continuous (at 550 V)	642	743	743	866	866	962	1079	1079	1079	1282
Continuous (at 575 V)	613	711	711	828	828	920	1032	1032	1032	1227
Continuous (at 690 V)	613	711	711	828	828	920	1032	1032	1032	1227
Power losses [W]										
Drive modules at 575 V	7469	8683	8668	10166	10163	11406	11292	12852	12835	15762
Drive modules at 690 V	7381	8559	8555	9996	9987	11188	11077	12580	12551	15358
AC bus bars at 575 V	637	644	644	653	653	661	661	672	672	695
DC bus bars during regeneration	198	198	208	208	218	218	231	231	256	256
Maximum cable size [mm ² (mcm)]										
Mains	4x120 (250)		6x120 (250)				8x120 (250)			
Motor	4x120 (250)		6x120 (250)				8x120 (250)			
Brake	8x70 (2/0)					8x95 (3/0)				
Regeneration terminals ¹⁾	4x150 (300)		6x120 (250)				6x150 (300)		8x120 (250)	
Maximum external mains fuses										
6-pulse configuration	700 V, 1600 A							700 V, 2000 A		
12-pulse configuration	700 V, 900 A					700 V, 1500 A				

7

Table 7.9 FC 202, 525–690 V AC Mains Supply (4-Drive System)

1) If Danfoss bus bar kit is used.

7.1.3 VLT® AutomationDrive FC 302

Power range	N250		N315		N355		N400		N450	
Drive modules	2		2		2		2		2	
Rectifier configuration	12-pulse								6-pulse/12-pulse	
High/normal load	HO	NO	HO	NO	HO	NO	HO	NO	HO	NO
Output current [A]										
Continuous (at 380–440 V)	480	588	600	658	658	745	695	800	810	880
Intermittent (60 s overload) at 400 V	720	647	900	724	987	820	1043	880	1215	968
Continuous (at 460/500 V)	443	535	540	590	590	678	678	730	730	780
Intermittent (60 s overload) at 460/500 V	665	588	810	649	885	746	1017	803	1095	858
Input current [A]										
Continuous (at 400 V)	463	567	590	647	647	733	684	787	779	857
Continuous (at 460/500 V)	427	516	531	580	580	667	667	718	711	759
Power losses [W]										
Drive modules at 400 V	4505	5825	5502	6110	6110	7069	6375	7538	7526	8468
Drive modules at 460 V	4063	4998	5384	5964	5721	6175	6070	6609	6604	7140
AC bus bars at 400 V	545	550	551	555	555	561	557	565	566	575
AC bus bars at 460 V	543	548	548	551	556	556	556	560	560	563
Maximum cable size [mm² (mcm)]										
Mains	4x120 (250)								4x150 (300)	
Motor	4x120 (250)								4x150 (300)	
Brake	4x70 (2/0)								4x95 (3/0)	
Regeneration terminals ¹⁾	4x120 (250)				4x150 (300)			6x120 (250)		
Maximum external mains fuses										
6-pulse configuration	–		–		–		–		600 V, 1600 A	
12-pulse configuration	600 V, 700 A								600 V, 900 A	

Table 7.10 FC 302, 380–500 V AC Mains Supply (2-Drive System)

1) If Danfoss bus bar kit is used.

Power range	N500		N560		N630		N710		N800	
Drive modules	4		4		4		4		4	
Rectifier configuration	6-pulse/12-pulse									
High/normal load	HO	NO	HO	NO	HO	NO	HO	NO	HO	NO
Output current [A]										
Continuous (at 380–440 V)	880	990	990	1120	1120	1260	1260	1460	1460	1720
Intermittent (60 s overload) at 400 V	1320	1089	1485	1232	1680	1386	1890	1606	2190	1892
Continuous (at 460/500 V)	780	890	890	1050	1050	1160	1160	1380	1380	1530
Intermittent (60 s overload) at 460/500 V	1170	979	1335	1155	1575	1276	1740	1518	2070	1683
Input current [A]										
Continuous (at 400 V)	857	964	964	1090	1090	1227	1227	1422	1422	1675
Continuous (at 460/500 V)	759	867	867	1022	1022	1129	1129	1344	1344	1490
Power losses [W]										
Drive modules at 400 V	7713	8810	8918	10199	10181	11632	11390	13253	13479	16463
Drive modules at 460 V	6641	7628	7855	9324	9316	10375	12391	12391	12376	13958
AC bus bars at 400 V	655	665	665	680	680	695	695	722	722	762
AC bus bars at 460 V	647	656	656	671	671	683	683	710	710	732
DC bus bars during regeneration	218	218	232	232	250	276	276	276	318	318
Maximum cable size [mm² (mcm)]										
Mains	4x185 (350)			8x120 (250)						
Motor	4x185 (350)			8x120 (250)						
Brake	8x70 (2/0)						8x95 (3/0)			
Regeneration terminals ¹⁾	6x125 (250)			8x125 (250)			8x150 (300)		10x150 (300)	
Maximum external mains fuses										
6-pulse configuration	600 V, 1600 A			600 V, 2000 A			600 V, 2500 A			
12-pulse configuration	600 V, 900 A					600 V, 1500 A				

7

Table 7.11 FC 302, 380–500 V AC Mains Supply (4-Drive System)

1) If Danfoss bus bar kit is used.

Power range	N250		N315		N355		N400	
Drive modules	2		2		2		2	
Rectifier configuration	12-pulse							
High/normal load	HO	NO	HO	NO	HO	NO	HO	NO
Output current [A]								
Continuous (at 550 V)	303	360	360	418	395	470	429	523
Intermittent (60 s overload) at 550 V	455	396	560	360	593	517	644	575
Continuous (at 575/690 V)	290	344	344	400	380	450	410	500
Intermittent (60 s overload) at 575/690 V	435	378	516	440	570	495	615	550
Input current [A]								
Continuous (at 550 V)	299	355	355	408	381	453	413	504
Continuous (at 575 V)	286	339	339	490	366	434	395	482
Continuous (at 690 V)	296	352	352	400	366	434	395	482
Power losses [W]								
Drive modules at 600 V	3688	4401	4081	4789	4502	5457	4892	6076
Drive modules at 690 V	3669	4352	4020	4709	4447	5354	4797	5951
AC bus bars at 575 V	538	540	540	541	540	544	542	546
DC bus bars during regeneration	88	88	89	89	90	90	91	91
Maximum cable size [mm² (mcm)]								
Mains	2x120 (250)			4x120 (250)				
Motor	2x120 (250)			4x120 (250)				
Brake	4x70 (2/0)							
Regeneration terminals ¹⁾	4x120 (250)							
Maximum external mains fuses	700 V, 550 A							

Table 7.12 FC 302, 525–690 V AC Mains Supply (2-Drive System)

1) If Danfoss bus bar kit is used.

Power range	N500		N560	
	Drive modules	2		2
Rectifier configuration	12-pulse			
High/normal load	HO	NO	HO	NO
Output current [A]				
Continuous (at 550 V)	523	596	596	630
Intermittent (60 s overload) at 550 V	785	656	894	693
Continuous (at 575/690 V)	500	570	570	630
Intermittent (60 s overload) at 575/690 V	750	627	627	693
Input current [A]				
Continuous (at 550 V)	504	574	574	607
Continuous (at 575 V)	482	549	549	607
Continuous (at 690 V)	482	549	549	607
Power losses [W]				
Drive modules at 600 V	6016	6995	6941	7431
Drive modules at 690 V	5886	6831	6766	7638
AC bus bars at 575 V	546	550	550	553
DC bus bars during regeneration	186	186	191	191
Maximum cable size [mm² (mcm)]				
Mains	4x120 (250)			
Motor	4x120 (250)			
Brake	4x95 (3/0)			
Regeneration terminals ¹⁾	4x120 (250)			
Maximum external mains fuses	700 V, 630 A			

7

Table 7.13 FC 302, 525–690 V AC Mains Supply (2-Drive System)

1) If Danfoss bus bar kit is used.

Power range	N630		N710		N800		N900		N1M0	
Drive modules	4		4		4		4		4	
Rectifier configuration	6-pulse/12-pulse									
High/normal load	HO	NO	HO	NO	HO	NO	HO	NO	HO	NO
Output current [A]										
Continuous (at 550 V)	659	763	763	889	889	988	988	1108	1108	1317
Intermittent (60 s overload) at 550 V	989	839	1145	978	1334	1087	1482	1219	1662	1449
Continuous (at 575/690 V)	630	730	730	850	850	945	945	1060	1060	1260
Intermittent (60 s overload) at 575/690 V	945	803	1095	935	1275	1040	1418	1166	1590	1590
Input current [A]										
Continuous (at 550 V)	642	743	743	866	866	962	1079	1079	1079	1282
Continuous (at 575 V)	613	711	711	828	828	920	1032	1032	1032	1227
Continuous (at 690 V)	613	711	711	828	828	920	1032	1032	1032	1227
Power losses [W]										
Drive modules at 600 V	7469	8683	8668	10166	10163	11406	11292	12852	12835	15762
Drive modules at 690 V	7381	8559	8555	9996	9987	11188	11077	12580	12551	15358
AC bus bars at 575 V	637	644	644	653	653	661	661	672	672	695
DC bus bars during regeneration	198	198	208	208	218	218	231	231	256	256
Maximum cable size [mm² (mcm)]										
Mains	4x120 (250)		6x120 (250)				8x120 (250)			
Motor	4x120 (250)		6x120 (250)				8x120 (250)			
Brake	8x70 (2/0)						8x95 (3/0)			
Regeneration terminals ¹⁾	4x150 (300)		6x120 (250)				6x150 (300)		8x120 (250)	
Maximum external mains fuses										
6-pulse configuration	700 V, 1600 A								700 V, 2000 A	
12-pulse configuration	700 V, 900 A						700 V, 1500 A			

Table 7.14 FC 302, 525–690 V AC Mains Supply (4-Drive System)

1) If Danfoss bus bar kit is used.

7.2 Mains Supply to Drive Module

Mains supply¹⁾

Supply terminals	R/91, S/92, T/93
Supply voltage ²⁾	380–480, 500 V 690 V, $\pm 10\%$, 525–690 V $\pm 10\%$
Supply frequency	50/60 Hz $\pm 5\%$
Maximum temporary imbalance between mains phases	3.0% of rated supply voltage
True power factor (λ)	≥ 0.98 nominal at rated load
Displacement power factor ($\cos \Phi$)	(Approximately 1)
Switching on input supply L1, L2, L3	Maximum 1 time per 2 minutes
Environment according to EN 60664-1	Overvoltage category III/pollution degree 2

1) The unit is suitable for use on a circuit capable of delivering not more than 85000 RMS symmetrical Amperes, 480/600 V.

2) Mains voltage low/mains voltage drop-out:

During low mains voltage, the drive module continues until the DC-link voltage drops below the minimum stop level, which corresponds typically to 15% below the lowest rated supply voltage. Power-up and full torque cannot be expected at mains voltage lower than 10% below the lowest rated supply voltage. The drive module trips for a detected mains drop-out.

7.3 Motor Output and Motor Data

Motor output

Motor terminals	U/96, V/97, W/98
Output voltage	0–100% of supply voltage
Output frequency	0–590 Hz
Switching on output	Unlimited
Ramp times	1–3600 s

Torque characteristics

Overload torque (constant torque)	Maximum 150% for 60 s ¹⁾
Starting torque	Maximum 180% up to 0.5 s ¹⁾
Overload torque (variable torque)	Maximum 110% for s ¹⁾
Starting torque (variable torque)	Maximum 135% for s

1) Percentage relates to the nominal torque.

Efficiency

Efficiency	98% ¹⁾
------------	-------------------

1) Efficiency measured at nominal current. For energy efficiency class, see . For part load losses, see www.danfoss.com/vltenergyefficiency.

7.4 12-Pulse Transformer Specifications

Connection	Dy11 d0 or Dyn 11d0
Phase shift between secondaries	30°
Voltage difference between secondaries	<0.5%
Short circuit impedance of secondaries	>5%
Short circuit impedance difference between secondaries	<5% of short circuit impedance
Other	No grounding of the secondaries allowed. Static shield recommended

7.5 Ambient Conditions for Drive Modules

Environment

IP rating	IP00
Acoustic noise	84 dB (running at full load)
Vibration test	1.0 g
Vibration and shock (IEC 60721-33-3)	Class 3M3
Maximum relative humidity	5–95% (IEC 721–3–3; Class 3K3 (non-condensing)) during operation

Aggressive environment (IEC 60068-2-43) H ₂ S test	Class Kd
Aggressive gases (IEC 60721-3-3)	Class 3C3
Ambient temperature ¹⁾	Maximum 45 °C (113 °F) (24-hour average maximum 40 °C (104 °F))
Minimum ambient temperature during full-scale operation	0 °C (32 °F)
Minimum ambient temperature at reduced performance	-10 °C (14 °F)
Temperature during storage/transport	-25 to +65 °C (-13 to 149 °F)
Maximum altitude above sea level without derating ¹⁾	1000 m (3281 ft)
EMC standards, Emission	EN 61800-3
EMC standards, Immunity	EN 61800-4-2, EN 61800-4-3, EN 61800-4-4, EN 61800-4-5, and EN 61800-4-6
Energy efficiency class ²⁾	IE2

1) Refer to the VLT® Parallel Drive Modules Design Guide for derating for high ambient temperature and derating for high altitude.

2) Determined according to EN 50598-2 at:

- Rated load.
- 90% rated frequency.
- Switching frequency factory setting.
- Switching pattern factory setting.

7

7.6 Cable Specifications

Cable lengths and cross-sections for control cables¹⁾

Maximum motor cable length, shielded	150 m (492 ft)
Maximum motor cable length, unshielded	300 m (984 ft)
Maximum cross-section to control terminals, flexible or rigid wire without cable end sleeves	1.5 mm ² /16 AWG
Maximum cross-section to control terminals, flexible wire with cable end sleeves	1 mm ² /18 AWG
Maximum cross-section to control terminals, flexible wire with cable end sleeves with collar	0.5 mm ² /20 AWG
Minimum cross-section to control terminals	0.25 mm ² /24 AWG
Maximum cross-section to 230 V terminals	2.5 mm ² /14 AWG
Minimum cross-section to 230 V terminals	0.25 mm ² /24 AWG

1) For power cables, see electrical data tables in chapter 7.1 Power-dependent Specifications.

7.7 Control Input/Output and Control Data

Digital inputs

Programmable digital inputs	4 (6) ¹⁾
Terminal number	18, 19, 27 ¹⁾ , 29 ¹⁾ , 32, 33
Logic	PNP or NPN
Voltage level	0–24 V DC
Voltage level, logic 0 PNP	<5 V DC
Voltage level, logic 1 PNP	>10 V DC
Voltage level, logic 0 NPN ²⁾	>19 V DC
Voltage level, logic 1 NPN ²⁾	<14 V DC
Maximum voltage on input	28 V DC
Pulse frequency range	0–110 kHz
(Duty cycle) Minimum pulse width	4.5 ms
Input resistance, R _i	Approximately 4 kΩ

All digital inputs are galvanically isolated from the supply voltage (PELV) and other high voltage terminals.

1) Terminals 27 and 29 can also be programmed as output.

2) Except Safe Torque Off input terminal 37.

Safe Torque Off (STO) Terminal 37^{1), 2)} (Terminal 37 is fixed PNP logic)

Voltage level	0–24 V DC
Voltage level, logic 0 PNP	<4 V DC
Voltage level, logic 1 PNP	>20 V DC
Maximum voltage on input	28 V DC
Typical input current at 24 V	50 mA _{rms}
Typical input current at 20 V	60 mA _{rms}
Input capacitance	400 nF

All digital inputs are galvanically isolated from the supply voltage (PELV) and other high voltage terminals.

1) See VLT[®] Frequency Converters – Safe Torque Off Operating Guide for further information about terminal 37 and Safe Torque Off.

2) When using a contactor with a DC coil with STO, always make a return path for the current from the coil when turning it off. The return path can be made by using a freewheel diode across the coil. Alternatively, use a 30 V or 50 V MOV for quicker response time. Typical contactors can be bought with this diode.

Analog inputs

Number of analog inputs	2
Terminal number	53, 54
Modes	Voltage or current
Mode select	Switch S201 and switch S202
Voltage mode	Switch S201/switch S202 = OFF (U)
Voltage level	-10 V to +10 V (scalable)
Input resistance, R _i	Approximately 10 kΩ
Maximum voltage	±20 V
Current mode	Switch S201/switch S202 = ON (I)
Current level	0/4–20 mA (scalable)
Input resistance, R _i	Approximately 200 Ω
Maximum current	30 mA
Resolution for analog inputs	10 bit (+ sign)
Accuracy of analog inputs	Maximum error 0.5% of full scale
Bandwidth	20 Hz/100 Hz

The analog inputs are galvanically isolated from the supply voltage (PELV) and other high voltage terminals.

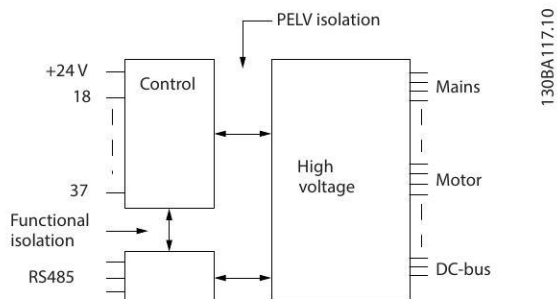

Illustration 7.1 PELV Isolation

Pulse input

Programmable pulse	2/1
Terminal number pulse	29 ¹⁾ , 32/33
Maximum frequency at terminal 29, 33	110 kHz (Push-pull driven)
Maximum frequency at terminal 29, 33	5 kHz (open collector)
Minimum frequency at terminal 29, 33	4 Hz
Voltage level	0–24 V DC
Maximum voltage on input	28 V DC
Input resistance, R _i	Approximately 4 kΩ
Pulse input accuracy (0.1–1 kHz)	Maximum error: 0.1% of full scale

Specifications
VLT® Parallel Drive Modules

Encoder input accuracy (1–11 kHz) Maximum error: 0.05% of full scale

The pulse and encoder inputs (terminals 29, 32, 33) are galvanically isolated from the supply voltage (PELV) and other high voltage terminals.

1) Pulse inputs are 29 and 33.

Analog output

Number of programmable analog outputs	1
Terminal number	42
Current range at analog output	0/4–20 mA
Maximum load GND - analog output	500 Ω
Accuracy on analog output	Maximum error: 0.5% of full scale
Resolution on analog output	12 bit

The analog output is galvanically isolated from the supply voltage (PELV) and other high voltage terminals.

Control card, RS485 serial communication

Terminal number	68 (P, TX+, RX+), 69 (N, TX-, RX-)
Terminal number 61	Common for terminals 68 and 69

The RS485 serial communication circuit is functionally separated from other central circuits and galvanically isolated from the supply voltage (PELV).

Digital output

Programmable digital/pulse outputs	2
Terminal number	27, 29 ¹⁾
Voltage level at digital/frequency output	0–24 V
Maximum output current (sink or source)	40 mA
Maximum load at frequency output	1 kΩ
Maximum capacitive load at frequency output	10 nF
Minimum output frequency at frequency output	0 Hz
Maximum output frequency at frequency output	32 kHz
Accuracy of frequency output	Maximum error: 0.1% of full scale
Resolution of frequency outputs	12 bit

1) Terminals 27 and 29 can also be programmed as input.

The digital output is galvanically isolated from the supply voltage (PELV) and other high voltage terminals.

Control card, 24 V DC output

Terminal number	12, 13
Output voltage	24 V +1, -3 V
Maximum load	200 mA

The 24 V DC supply is galvanically isolated from the supply voltage (PELV), but has the same potential as the analog and digital inputs and outputs.

Relay outputs

Programmable relay outputs	2
Relay 01 terminal number	1–3 (break), 1–2 (make)
Maximum terminal load (AC-1) ¹⁾ on 1–3 (NC), 1–2 (NO) (resistive load)	240 V AC, 2 A
Maximum terminal load (AC-15) ¹⁾ (inductive load @ cosφ 0.4)	240 V AC, 0.2 A
Maximum terminal load (DC-1) ¹⁾ on 1–2 (NO), 1–3 (NC) (resistive load)	60 V DC, 1 A
Maximum terminal load (DC-13) ¹⁾ (inductive load)	24 V DC, 0.1 A
Relay 02 (VLT® AutomationDrive FC 302 only) terminal number	4–6 (break), 4–5 (make)
Maximum terminal load (AC-1) ¹⁾ on 4–5 (NO) (resistive load) ²⁾³⁾ overvoltage category II	400 V AC, 2 A
Maximum terminal load (AC-15) ¹⁾ on 4–5 (NO) (inductive load @ cosφ 0.4)	240 V AC, 0.2 A
Maximum terminal load (DC-1) ¹⁾ on 4–5 (NO) (resistive load)	80 V DC, 2 A
Maximum terminal load (DC-13) ¹⁾ on 4–5 (NO) (inductive load)	24 V DC, 0.1 A
Maximum terminal load (AC-1) ¹⁾ on 4–6 (NC) (resistive load)	240 V AC, 2 A
Maximum terminal load (AC-15) ¹⁾ on 4–6 (NC) (inductive load @ cosφ 0.4)	240 V AC, 0.2 A
Maximum terminal load (DC-1) ¹⁾ on 4–6 (NC) (resistive load)	50 V DC, 2 A

Maximum terminal load (DC-13) ¹⁾ on 4–6 (NC) (inductive load)	24 V DC, 0.1 A
Minimum terminal load on 1–3 (NC), 1–2 (NO), 4–6 (NC), 4–5 (NO)	24 V DC 10 mA, 24 V AC 20 mA
Environment according to EN 60664-1	Overvoltage category III/pollution degree 2

1) IEC 60947 part 4 and 5.

The relay contacts are galvanically isolated from the rest of the circuit by reinforced isolation (PELV).

2) Overvoltage Category II.

3) UL applications 300 V AC 2A.

Control card, 10 V DC output

Terminal number	50
Output voltage	10.5 V ±0.5 V
Maximum load	25 mA

The 10 V DC supply is galvanically isolated from the supply voltage (PELV) and other high voltage terminals.

Control characteristics

Resolution of output frequency at 0–590 Hz	±0.003 Hz
Repeat accuracy of precise start/stop (terminals 18, 19)	≤±0.1 ms
System response time (terminals 18, 19, 27, 29, 32, 33)	≤10 ms
Speed control range (open loop)	1:100 of synchronous speed
Speed control range (closed loop)	1:1000 of synchronous speed
Speed accuracy (open loop)	30–4000 RPM: Error ±8 RPM
Speed accuracy (closed loop), depending on resolution of feedback device	0–6000 RPM: Error ±0.15 RPM

All control characteristics are based on a 4-pole asynchronous motor

Control card performance

Scan interval (VLT [®] HVAC Drive FC 102, VLT [®] Refrigeration Drive FC 103, VLT [®] AQUA Drive FC 202)	5 ms (VLT [®] Automation Drive FC 302)
Scan interval (FC 302)	1 ms

Control card, USB serial communication

USB standard	1.1 (full speed)
USB plug	USB type B device plug

Connection to PC is carried out via a standard host/device USB cable.

The USB connection is galvanically isolated from the supply voltage (PELV) and other high voltage terminals.

The USB ground connection is NOT galvanically isolated from protective earth. Use only an isolated laptop as PC connection to the USB connector on the frequency converter.

7

7.8 Kit Dimensions

7.8.1 Exterior Dimensions

Illustration 7.2 shows the dimensions of the drive module related to its installation.

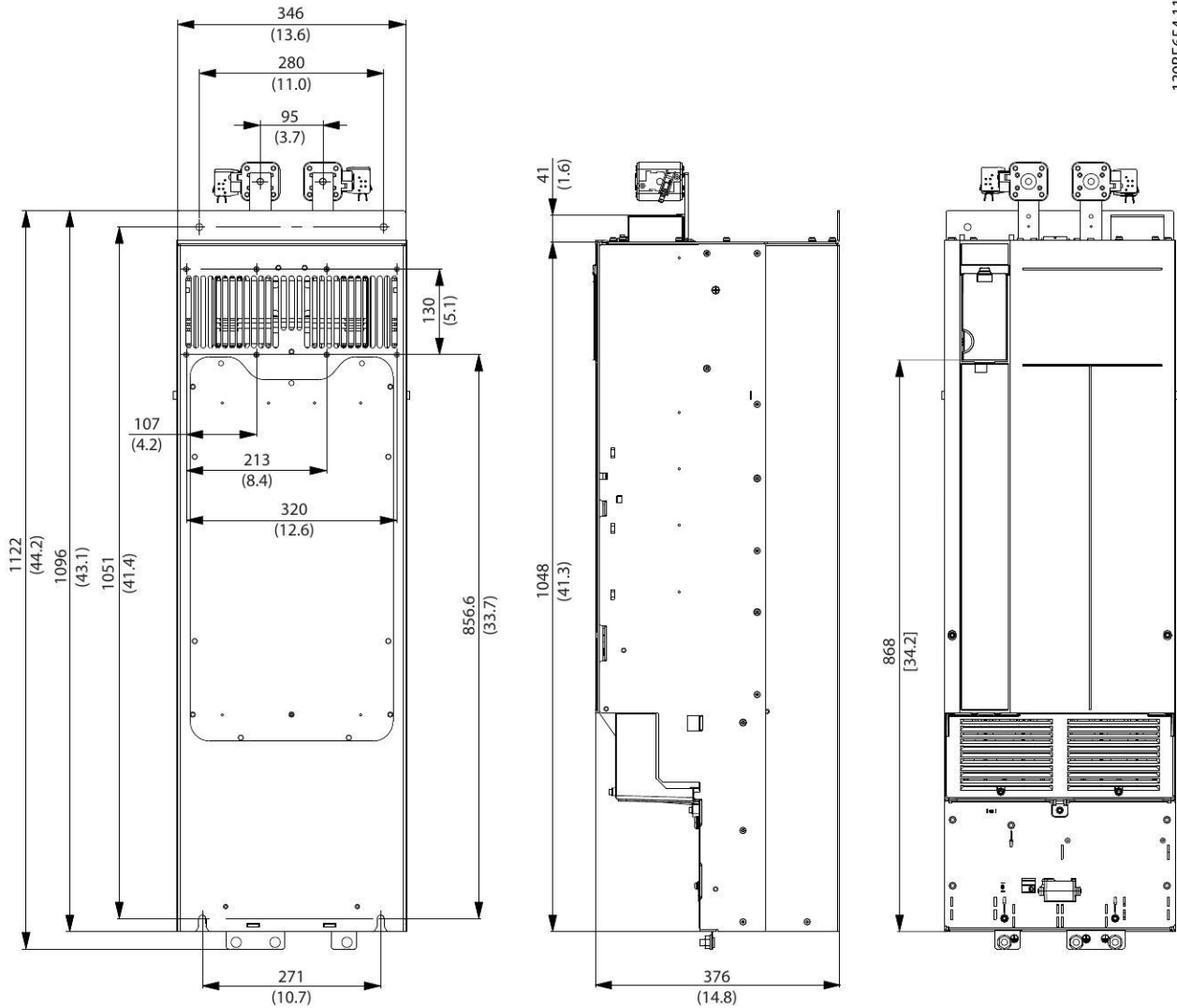

130BE654.11

Illustration 7.2 VLT® Parallel Drive Modules Installation Dimensions

Description	Module weight [kg (lb)]	Length x width x depth [mm (in)]
Drive module	125 (275)	1121.7 x 346.2 x 375 (44.2 x 13.6 x 14.8)

Table 7.15 Drive Module Weight and Dimensions

7.8.2 Terminal Dimensions

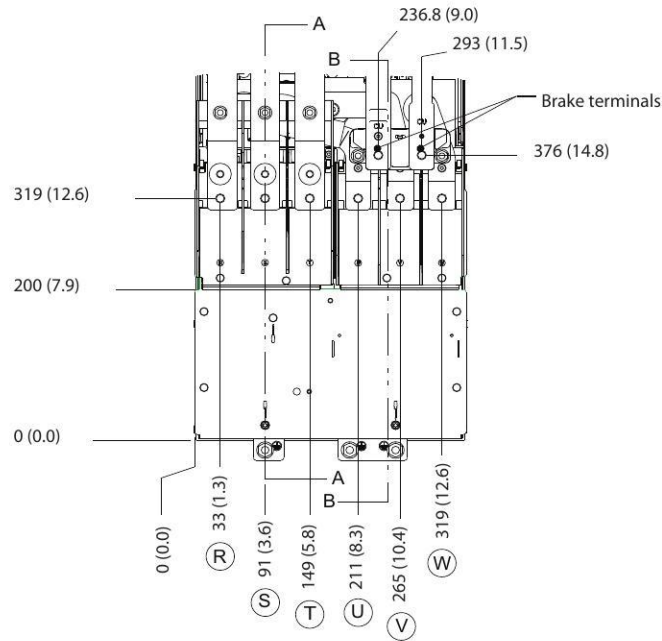

130BE/48.10

7

Illustration 7.3 Drive Module Terminal Dimensions (Front View)

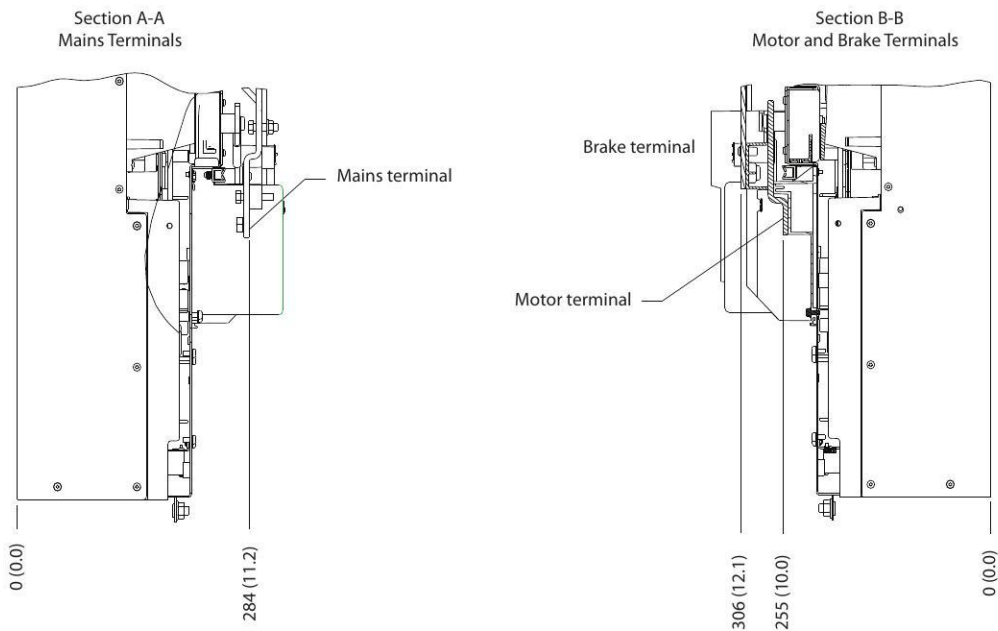

130BE/49.10

Illustration 7.4 Drive Module Terminal Dimensions (Side Views)

7.8.3 DC Bus Dimensions

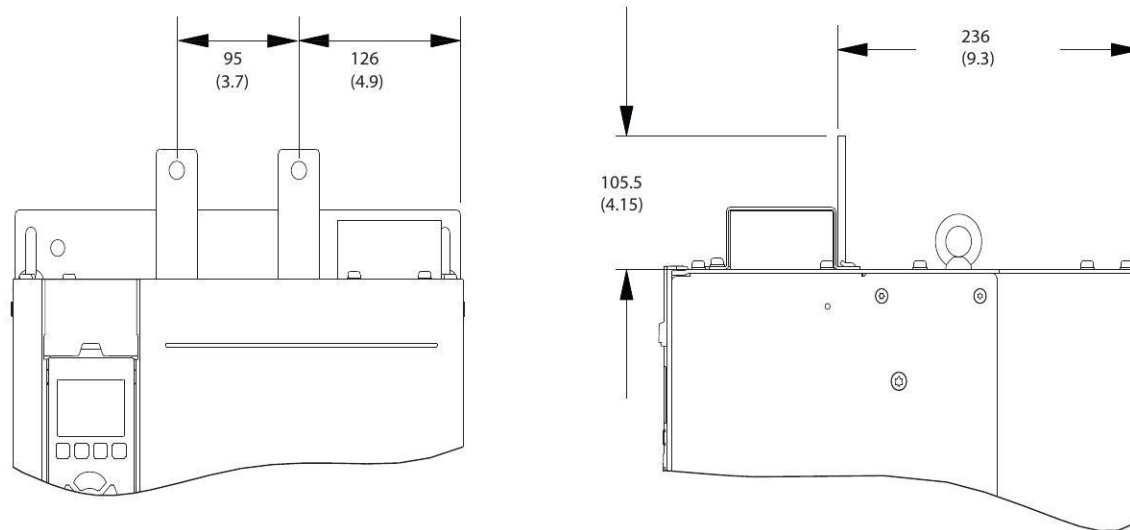

130BE751.10

Illustration 7.5 DC Bus Dimensions (Front and Side Views)

7

7.9 Fastener Tightening Torques

For fastening hardware described in this manual, use the torque values in *Table 7.16*. These torque values are not intended for fastening IGBTs. See the instructions included with those replacement parts for the correct torque values.

Shaft size	Driver size Torx/hex	Torque (N · m)	Torque (in-lb)
M4	T20 Torx/7 mm hex	1.0	9
M5	T25 Torx/8 mm hex	2.3	20
M6	T30 Torx/10 mm hex	4.0	35
M8	T40 Torx/13 mm hex	9.6	85
M10	T50 Torx/17 mm hex	19.1	169
M12 (hex bolts only)	18 mm or 19 mm hex	19.1	169

Table 7.16 General Tightening Torques of Fasteners

7.9.1 Tightening Torques for Terminals

For fastening terminals, use the torque values in *Table 7.17*.

Bolt size	Mains	Motor	Regen	Load sharing	Ground	Brake
	M10	M10	M10	M10	M8	M8
Torque [N · m (in-lb)]	19–40 (168–354)	19–40 (168–354)	19–40 (168–354)	19–40 (168–354)	8.5–20.5 (75–181)	8.5–20.5 (75–181)

Table 7.17 Tightening of Terminals

8 Appendix

8.1 Disclaimer

Danfoss shall have no obligation with respect to any product that

- is not installed according to the standard configuration as specified in the installation guide.
- is improperly repaired or altered.
- is subjected to misuse, negligence, and improper installation where the guidelines were not followed.
- is used in a contradictory manner to the instructions provided.
- is a result of normal wear and tear.

Conventions

Numbered lists indicate procedures.

Bullet lists indicate other information and description of illustrations.

Italicized text indicates:

- Cross-references.
- Links.
- Parameter names.

All measurements are given in both metric units and imperial units. Imperial units are in ().

8.2 Symbols, Abbreviations, and Conventions

°C	Degrees Celsius
°F	Degrees Fahrenheit
AC	Alternating current
AWG	American wire gauge
DC	Direct current
EMC	Electro magnetic compatibility
ETR	Electronic thermal relay
FC	Frequency converter
IP	Ingress protection
LCP	Local control panel
MCT	Motion control tool
MDCI C	Multi-drive control interface
PCB	Printed circuit board
PELV	Protective extra low voltage
PM Motor	Permanent magnet motor
RCD	Residual current-operated protective device
Regen	Regenerative terminals
RFI	Radio frequency interference
RPM	Revolutions per minute

Table 8.1 Symbols and Abbreviations

8.3 Block Diagrams

8.3.1 Connection of 12-Pulse Disconnecter/Interlock

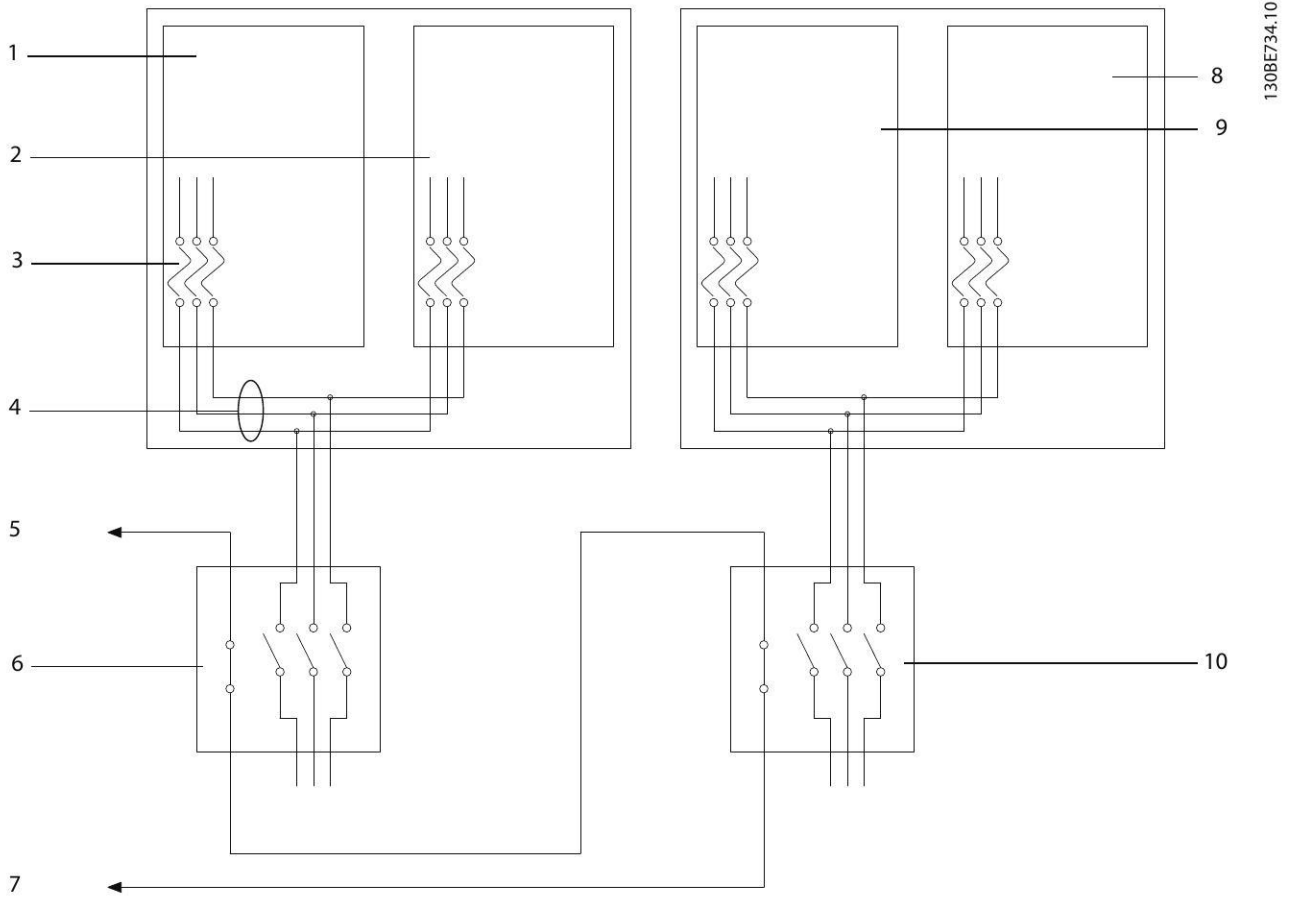

1	Drive module 1	6	Disconnecter 1
2	Drive module 2	7	Brake fault
3	Supplementary fuses	8	Drive module 3
4	Mains input bus bars	9	Drive module 4
5	Brake fault	10	Disconnecter 2

Illustration 8.1 Connection of 12-Pulse Disconnecter/Interlock

8.3.2 BRF Connection with 12-Pulse Disconnecter/Interlock

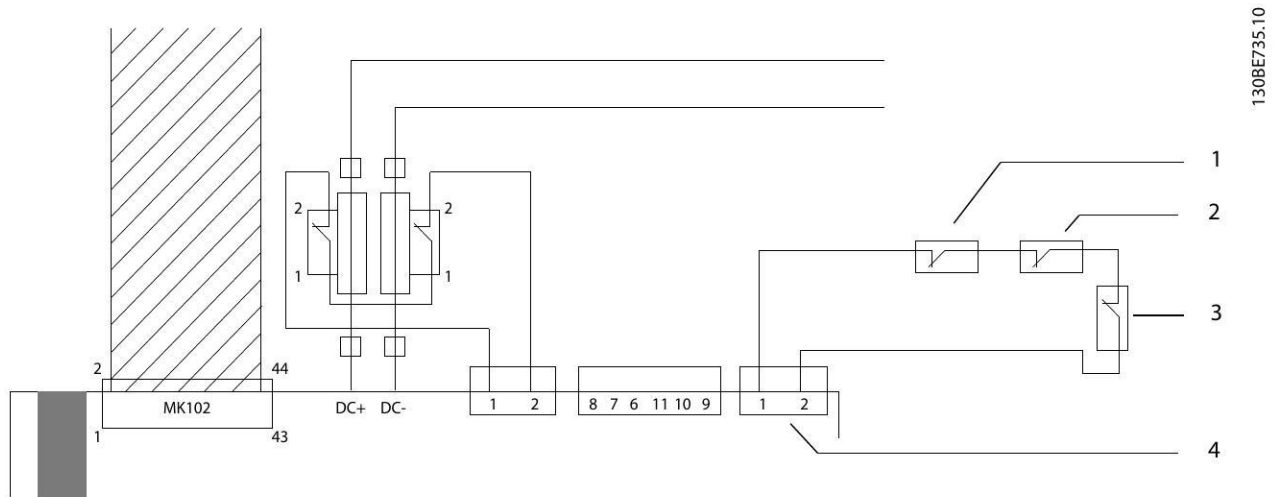

130BE735.10

1	Auxiliary contact disconnecter 1	3	Klixon switch
2	Auxiliary contact disconnecter 2	4	BRF connector

Illustration 8.2 BRF Connection with 12-Pulse Disconnecter/Interlock

8.3.3 BRF Jumper Connection

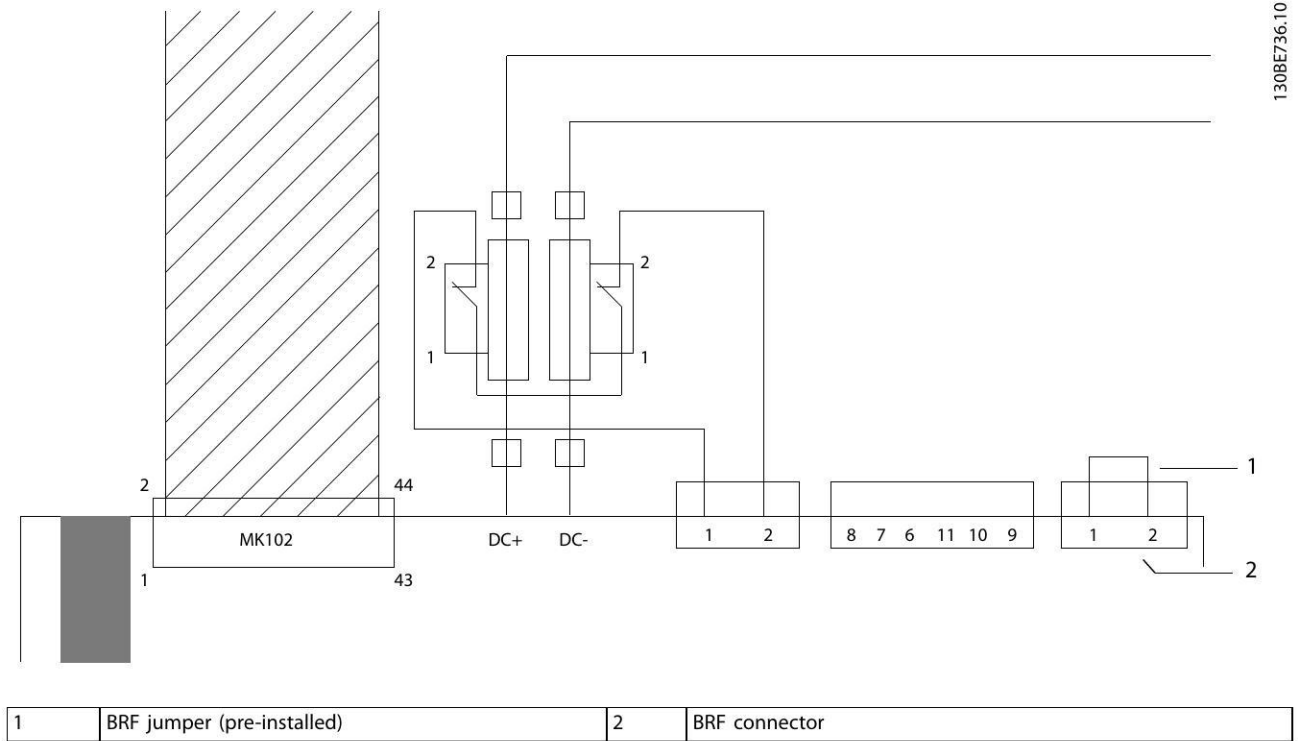
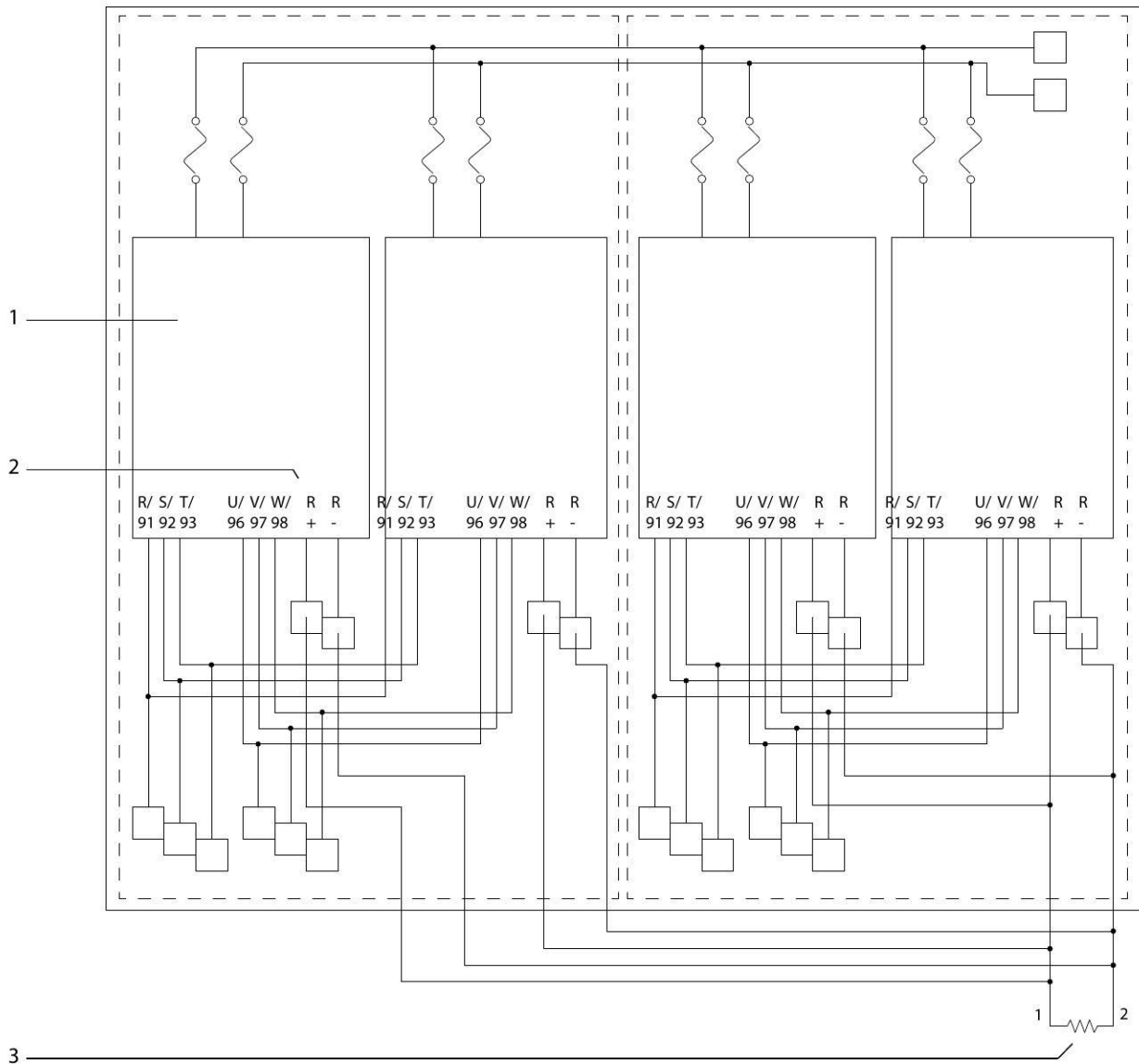

Illustration 8.3 BRF Jumper Connection

8.3.4 Connection of Common Brake Resistor



1	Drive module	3	Common brake resistor
2	Brake terminals	-	-

Illustration 8.4 Connection of Common Brake Resistor

8.3.5 Klixon Switch Connection

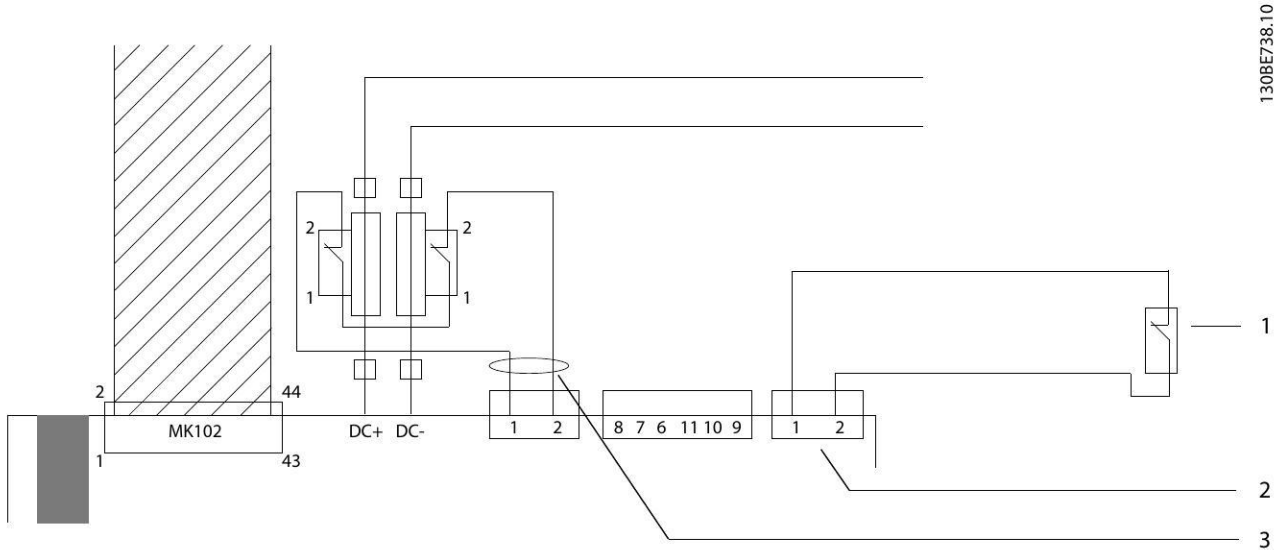

130BE738.10

8

1	Klixon switch	3	Ferrite core
2	BRF connector	-	-

Illustration 8.5 Klixon Switch Connection

8.3.6 Control Shelf Connections

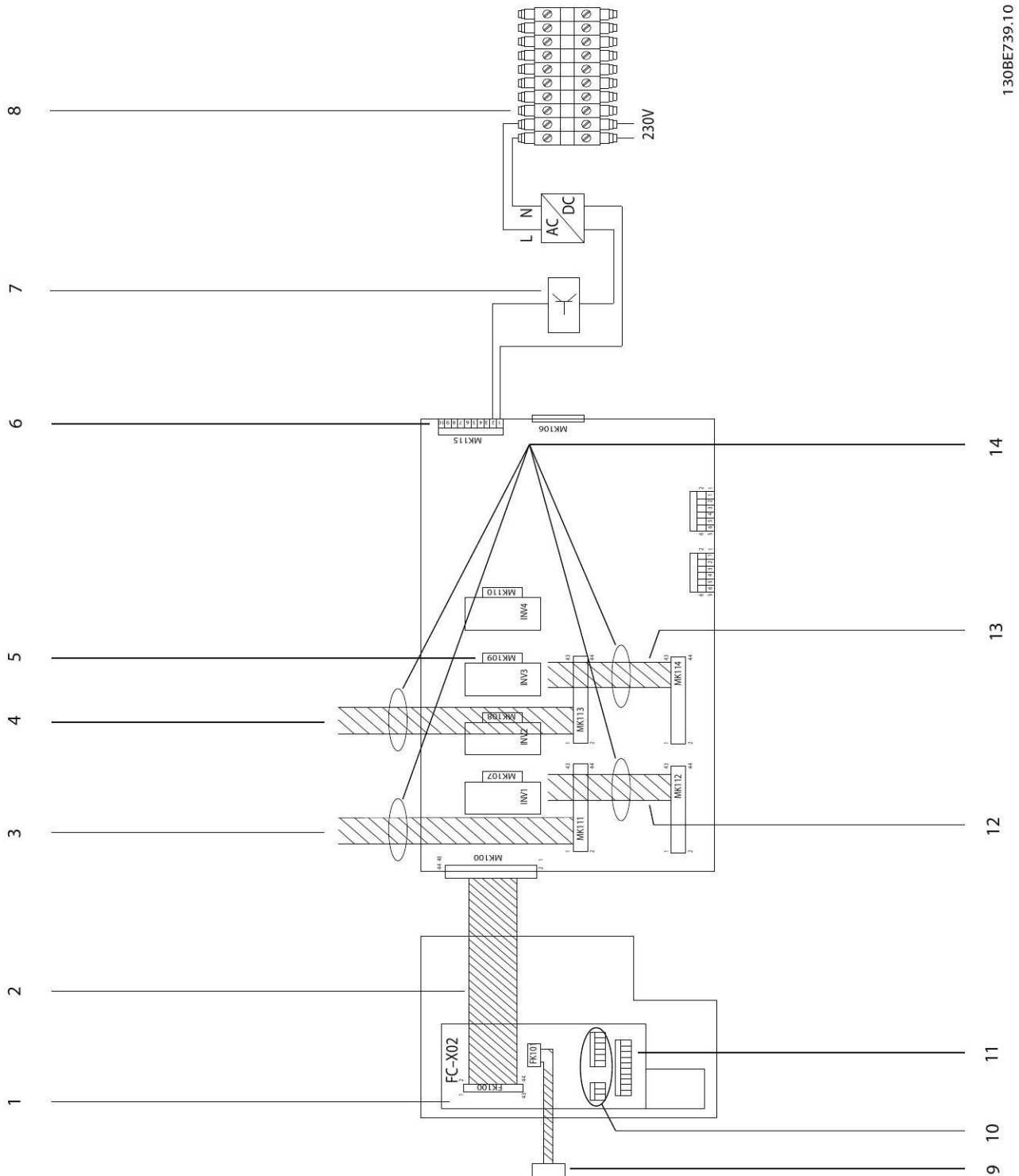

130BE739.10

1	LCP cradle	8	Terminal block
2	Ribbon cable from LCP to MDCIC	9	Cable to remote-mounted LCP
3	44-pin cable to the drive module 1 (at MK 111)	10	Analog I/O terminals
4	44-pin cable to the drive module 3 (at MK 113)	11	Digital input terminals
5	Current scaling card	12	44-pin cable to the drive module 2 (at MK 112)
6	STO connector	13	44-pin cable to the drive module 4 (at MK 114)
7	STO relay	14	Ferrite cores

Illustration 8.6 Control Shelf Connections

8.3.7 Discharge Resistor Connections

8

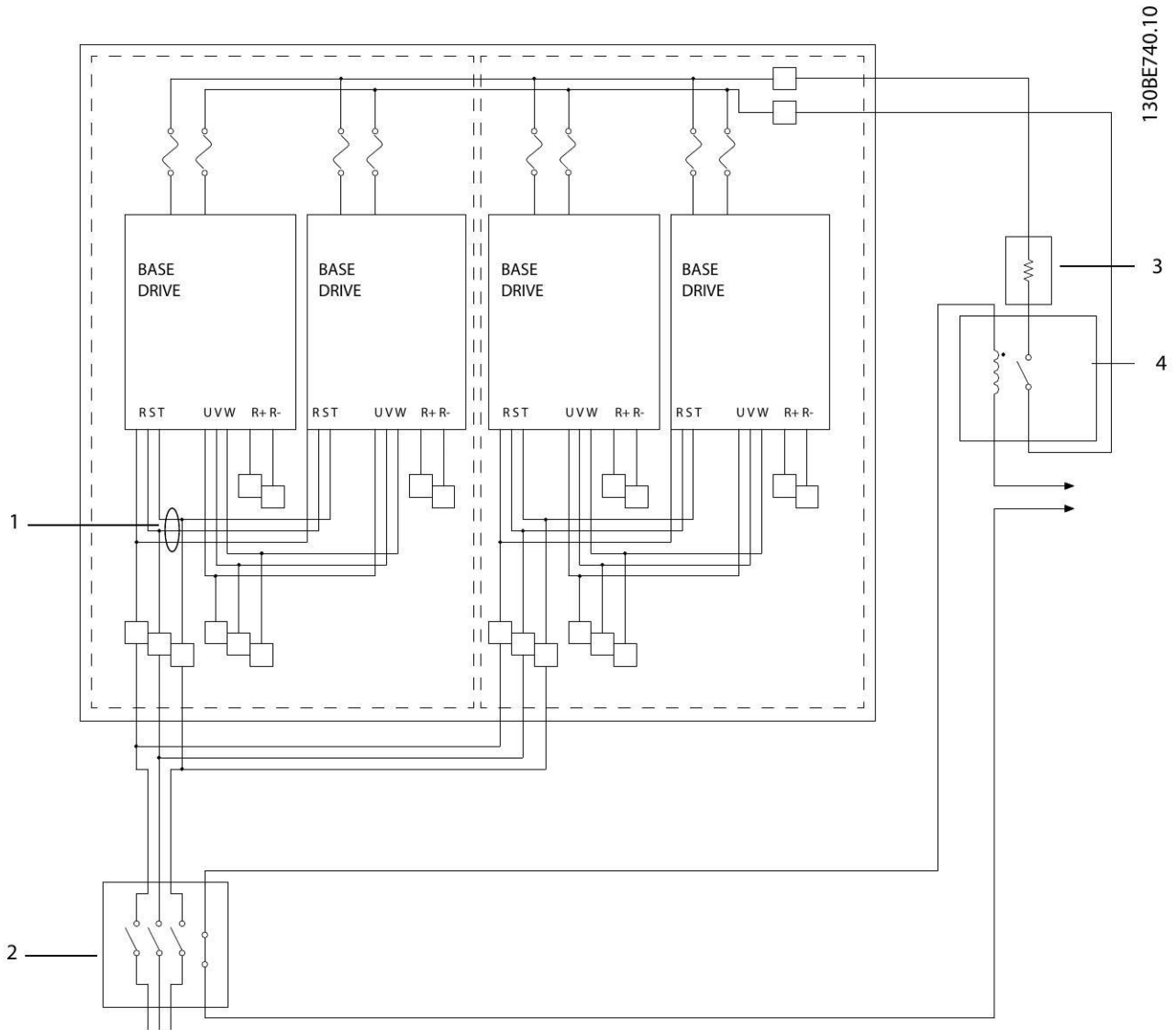

1	Mains input bus bars	3	Discharge resistor
2	Mains contactor/disconnector auxiliary contacts	4	Discharge contactor

Illustration 8.7 Discharge Resistor Connections

8.3.8 Connection of Individual Brake Resistor to Each Drive Module

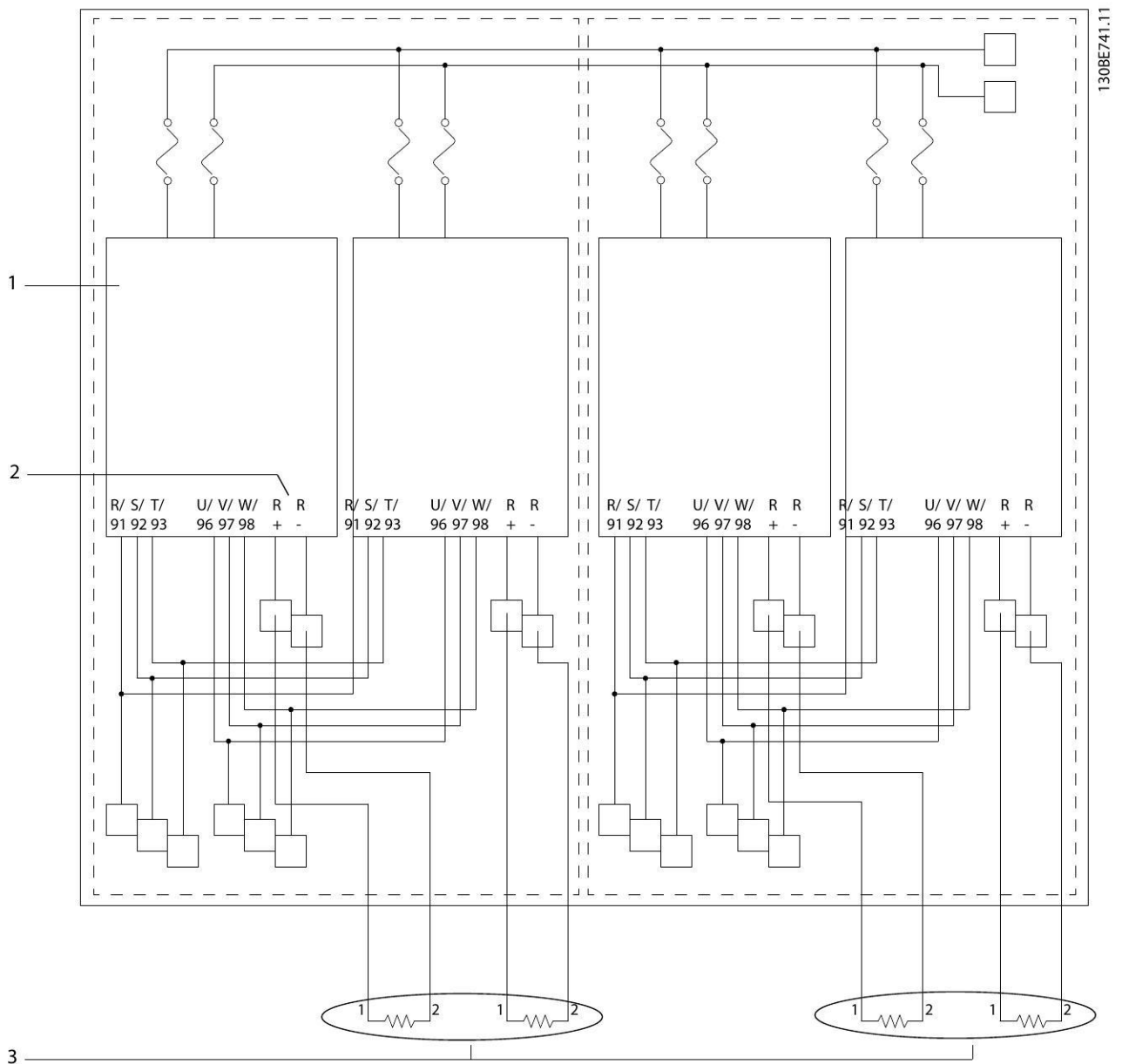

8

1	Drive module	3	Individual brake resistors
2	Brake terminals	-	-

Illustration 8.8 Connection of Individual Brake Resistor to Each Drive Module

8.3.9 Connections in a 6-Pulse 2-Drive Module System

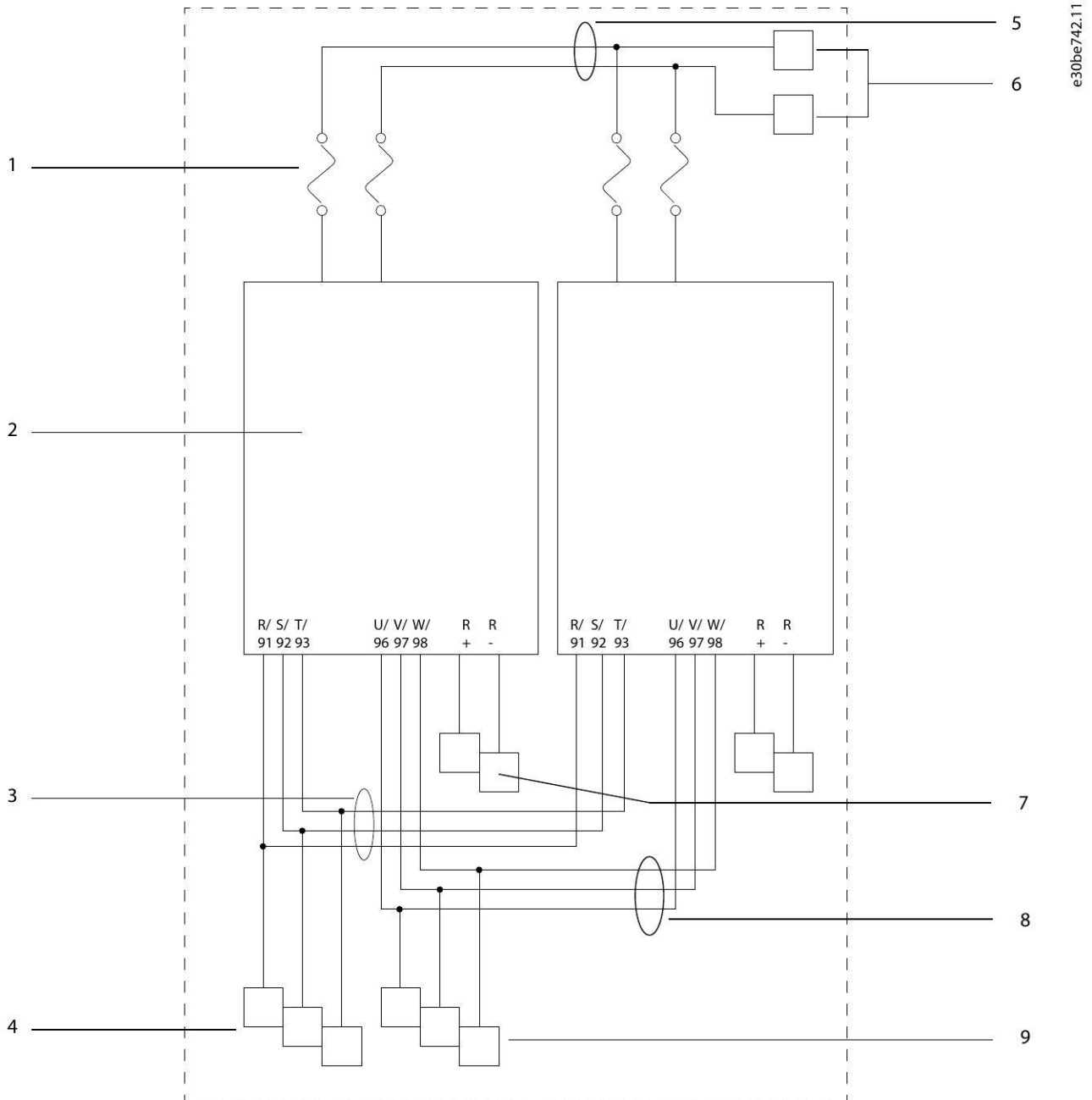

e30be/42.11

8

1	DC fuses	6	DC terminals
2	Drive module	7	Connection to brake
3	Mains input bus bars connecting both drive modules	8	Motor output bus bars connecting both drive modules
4	Connection to mains	9	Connection to motor output
5	DC-link bus bars connecting both drive modules	-	-

Illustration 8.9 Connections in a 6-Pulse 2-Drive Module System

8.3.10 Connections in a 12-Pulse 2-Drive Module System

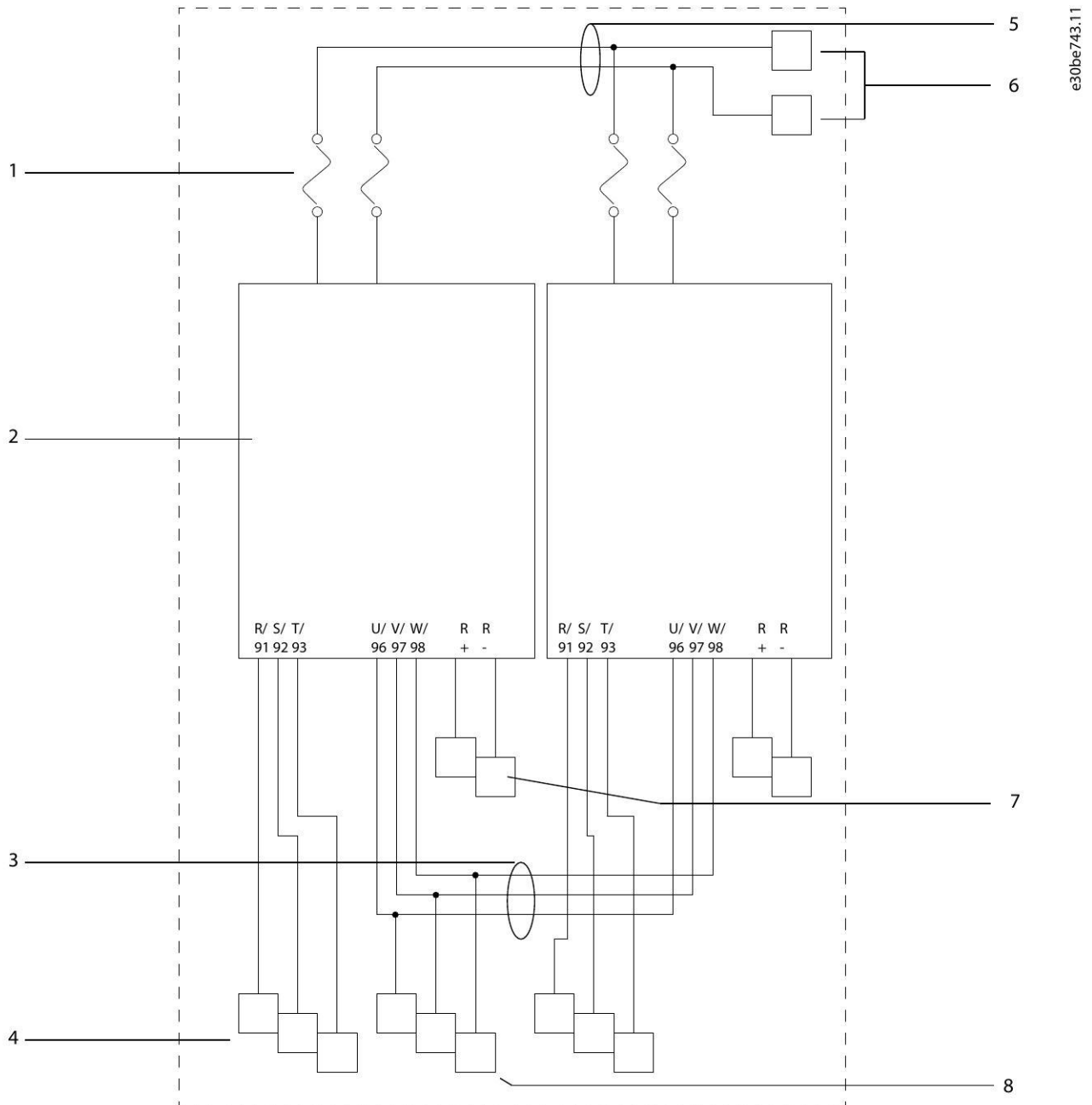

e30be/743.11

1	DC fuses	5	DC-link bus bars connecting both drive modules
2	Drive module	6	DC terminals
3	Motor output bus bars connecting both drive modules	7	Connection to brake
4	Connection to mains input	8	Connection to motor output

Illustration 8.10 Connections in a 12-Pulse 2-Drive Module System

8.3.11 Connections in a 4-Drive Module System

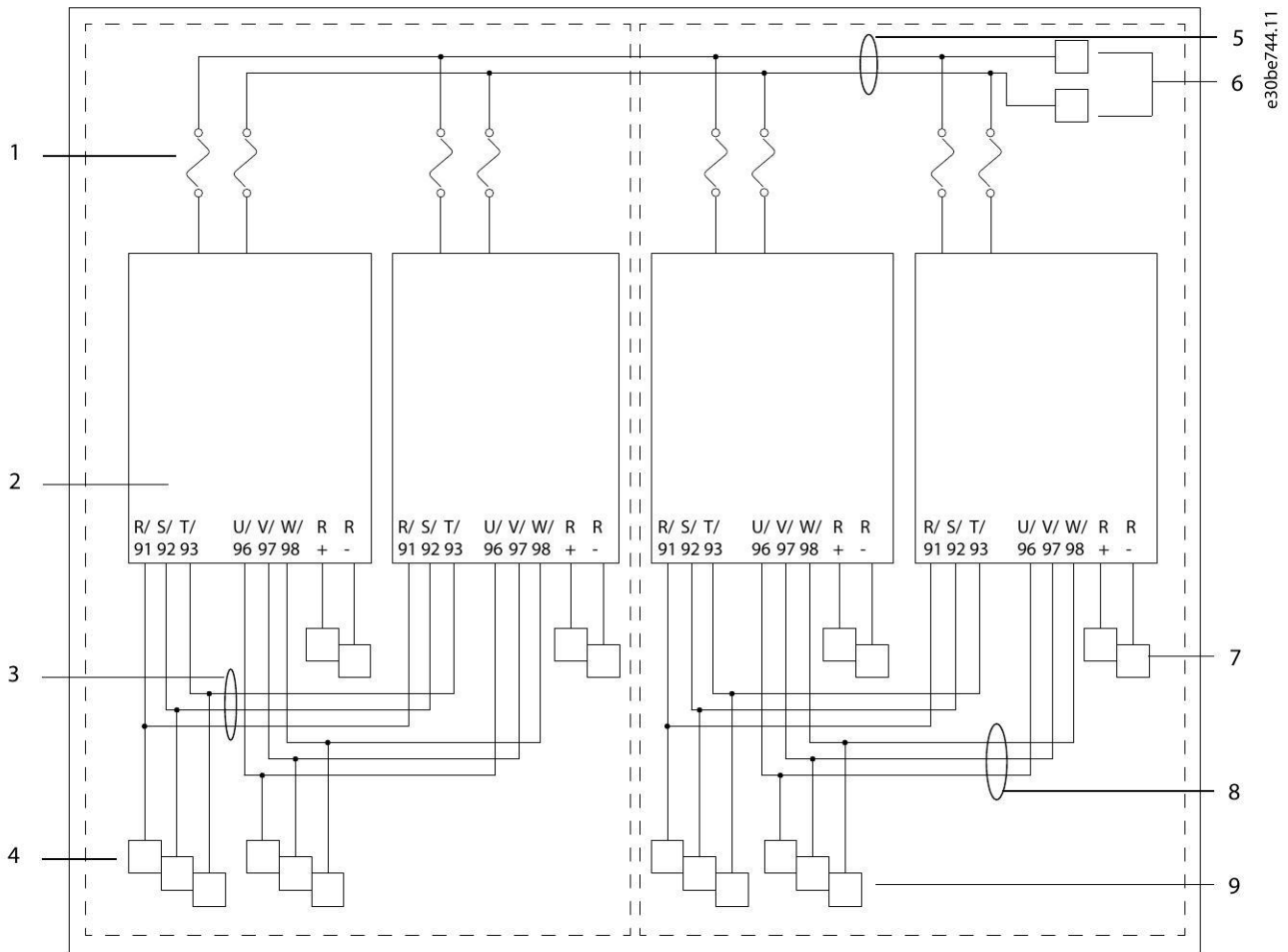

8

1	DC fuses	6	DC terminals
2	Drive module	7	Connection to brake
3	Mains input bus bars connecting 2 drive modules	8	Motor output bus bars connecting 2 drive modules
4	Connection to mains input	9	Connection to motor output
5	DC-link bus bars connecting all 4 drive modules	-	-

Illustration 8.11 Connections in a 4-Drive Module System

NOTICE

DRIVE MODULE WIRING

The installer must install an equal number of wires to each set of drive modules.

Index

A

A53 switch..... 35
 A54 switch..... 35
 Abbreviations..... 67
 AC mains..... 7, 28
 AC waveform..... 7
 Approvals..... 4

B

Bus termination switch..... 35
 Busbars..... 14

C

Cable
 Clamp..... 37
 Control..... 37, 39, 40
 Equalizing..... 40
 Motor..... 26, 37
 Routing..... 41
 Shielded..... 39, 40, 41
 CE compliance..... 22
 Certifications..... 4
 Circuit breakers..... 41
 Closed loop..... 35
 Conduit..... 41
 Configuration
 Mains..... 28
 Control
 card, USB serial communication..... 63
 Control system..... 7
 Control terminal..... 35
 Control terminal types..... 33
 Control wiring..... 41
 Conventions..... 67
 Cooling clearance..... 41

D

Discharge time..... 5
 Disconnect switch..... 42
 Disposal..... 4

E

Electronic thermal relay..... 19

EMC

Electrical installation guidelines..... 37
 EMC..... 40
 Precautions..... 37

Energy efficiency..... 59
 Energy efficiency class..... 59
 ETR..... 19
 External controllers..... 7

F

Fans..... 15
 Feedback..... 35, 41
 Fuses..... 19, 41

G

Ground connections..... 41
 Ground loop..... 40
 Grounding..... 27, 28, 29, 41, 42
 Grounding, shielded control cable..... 40

H

High voltage..... 5, 6, 42

I

Input
 Analog..... 33, 34
 Current..... 28
 Digital..... 33, 34, 35
 Power..... 41, 42
 Signal..... 35
 Terminal..... 35, 42
 Voltage..... 42
 Installation..... 41
 Interference isolation..... 41
 Items supplied..... 11

J

Jumper..... 35

K

KTY sensor..... 26

L

Leakage current (>3.5 mA)..... 6
 Lifting the unit..... 12

M

Mains
 Supply..... 59
 Mains terminal..... 35
 MCT 10 Set-up Software..... 33

<p>Motor</p> <ul style="list-style-type: none"> Cable..... 19, 26, 37 Output..... 59 Used with frequency converter..... 7 Wiring..... 41 <p>Mounting..... 41</p> <p>Multiple frequency converters..... 19</p> <p>N</p> <p>Nameplate..... 11</p> <p>O</p> <p>Open loop..... 35</p> <p>Optional equipment..... 35, 42</p> <p>Output</p> <ul style="list-style-type: none"> Analog..... 33, 34 Relay..... 33, 36, 62 Terminal..... 42 <p>Overcurrent protection..... 19</p> <p>P</p> <p>Power connection..... 19</p> <p>Power factor..... 41</p> <p>Precautions..... 37</p> <p>Programming..... 35</p> <p>Protection..... 22</p> <p>PTC thermistor card..... 25</p> <p>Q</p> <p>Qualified personnel..... 5</p> <p>R</p> <p>Recycling..... 4</p> <p>Relay..... 34, 62</p> <p>Remote commands..... 7</p> <p>RS485..... 36</p> <p>S</p> <p>Safe Torque Off..... 36</p> <p>Safety..... 5, 42</p> <p>Serial communication..... 7, 33, 34, 40</p> <p>Shielded twisted pair (STP)..... 36</p> <p>Short-circuit protection..... 22</p> <p>Speed reference..... 35</p> <p>STO..... 36</p> <p>Supply voltage..... 33, 34, 42</p> <p>Switch..... 35</p> <p>Symbols..... 67</p>	<p>System feedback..... 7</p> <p>T</p> <p>Terminal 53..... 35</p> <p>Terminal 54..... 35</p> <p>Terminals</p> <ul style="list-style-type: none"> Drive module dimensions..... 65 Terminals, tightening..... 66 <p>Thermistor..... 25, 33</p> <p>Thermistor control wiring..... 33</p> <p>Tightening, general..... 66</p> <p>Tightening, terminals..... 66</p> <p>Transformers used with 12-pulse..... 59</p> <p>U</p> <p>UL compliance..... 22</p> <p>Unintended start..... 5, 42</p> <p>V</p> <p>Voltage level..... 60</p> <p>W</p> <p>Warranty..... 11</p> <p>Weight..... 14, 64</p> <p>Wire sizes..... 19, 26</p> <p>Wiring</p> <ul style="list-style-type: none"> Control..... 41 Control terminal..... 35 Motor..... 41
---------------------------------------------------------------------------------------------------------------------------------------------------------------------------------------------------------------------------------------------------------------------------------------------------------------------------------------------------------------------------------------------------------------------------------------------------------------------------------------------------------------------------------------------------------------------------------------------------------------------------------------------------------------------------------------------------------------------------------------------------------------------------------------------------------------------------------------------------------------------------------------------------------------------------------------------------------------------------------------------------------------------------------------------------------------------------------------------------------------------------------------------------------------------------------------------------------------------------------------------------------------------------------------	-------------------------------------------------------------------------------------------------------------------------------------------------------------------------------------------------------------------------------------------------------------------------------------------------------------------------------------------------------------------------------------------------------------------------------------------------------------------------------------------------------------------------------------------------------------------------------------------------------------------------------------------------------------------------------------------------------------------------------------------------------------------------------------------------------------------



.....
Danfoss can accept no responsibility for possible errors in catalogues, brochures and other printed material. Danfoss reserves the right to alter its products without notice. This also applies to products already on order provided that such alterations can be made without subsequential changes being necessary in specifications already agreed. All trademarks in this material are property of the respective companies. Danfoss and the Danfoss logotype are trademarks of Danfoss A/S. All rights reserved.
.....

Danfoss A/S
Ulsnaes 1
DK-6300 Graasten
vlt-drives.danfoss.com

130R0657

MG37K302



08/2017



RSPSupply - 1-888-532-2706 - <https://www.RSPSupply.com>
See the product details here